

Adsorption dryer
KA-MT 10-95

Dokument-ID: DMN-KA-MT10-95/R02

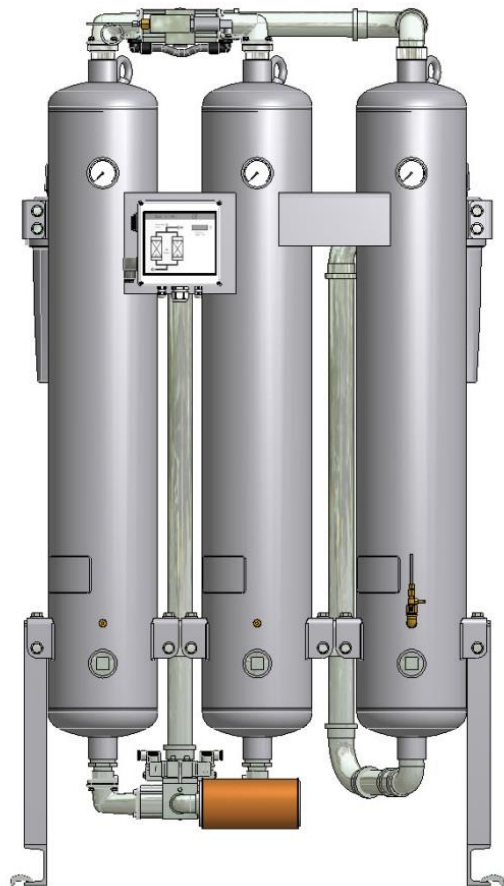

Operating instructions

Revision 02—07/2016/EN

CE 0525

Declaration of Conformity

Parker Hannifin Manufacturing Germany GmbH & Co. KG
Gas Separation and Filtration Division EMEA

Im Teelbruch 118

D – 45219 Essen Kettwig

hereby declares with sole responsibility, that the products

compressed air adsorption dryer

KA-MT 10 bis 95

assembly type: assembly acc. to Art. 4 No. 2b,

which this declaration refers to, conform to Directive **2014/68/EU** and were subjected to a conformity assessment according to Annex III Modules B + D (for assembly assessment).

The quality assurance system is monitored by the service provider stated below
Lloyd's Register Quality Assurance GmbH (identification number 0525)
Am Sandtorkai 41, D - 20457 Hamburg.

The assembly consists of pressure appliances according to the classification list (attached to the technical documentation provided by the manufacturer).

Pressure vessel					
Dryer	Quantity	Allowable pressure (PS)	Volume [l]	Category (PED)	Module
KA-MT 10	3	16	20	II	B + D
KA-MT 15	3	16	24	II	B + D
KA-MT 20	3	16	36	II	B + D
KA-MT 25	3	16	45	II	B + D
KA-MT 35	3	16	55	II	B + D
KA-MT 45	3	16	70	III	B + D
KA-MT 60	3	16	105	III	B + D
KA-MT 75	3	16	132	III	B + D
KA-MT 95	3	16	175	III	B + D

Piping				
Dryer	Allowable pressure (PS)	Dimensions (DN)	Category (PED)	Module
KA-MT 10	16	DN25	Art.4.3	Art.4.3
KA-MT 15	16	DN25	Art.4.3	Art.4.3
KA-MT 20	16	DN25	Art.4.3	Art.4.3
KA-MT 25	16	DN40	Art.4.3	Art.4.3
KA-MT 35	16	DN40	Art.4.3	Art.4.3
KA-MT 45	16	DN40	Art.4.3	Art.4.3
KA-MT 60	16	DN50	Art.4.3	Art.4.3
KA-MT 75	16	DN50	Art.4.3	Art.4.3
KA-MT 95	16	DN65	I	A

Filter						
Dryer	Filter	Quantity	Allowable pressure (PS)	Volume [l]	Category (PED)	Module
KA-MT 10	GL 9	2	16	1,1	Art.4.3	Art.4.3
KA-MT 15	GL 9	2	16	1,1	Art.4.3	Art.4.3
KA-MT 20	GL 9	2	16	2	Art.4.3	Art.4.3
KA-MT 25	GL 11	2	16	2	Art.4.3	Art.4.3
KA-MT 35	GL 11	2	16	2	Art.4.3	Art.4.3
KA-MT 45	GL 12	2	16	6	I	B+D
KA-MT 60	GL 13	2	16	6	I	B+D
KA-MT 75	GL 13	2	16	6	I	B+D
KA-MT 95	GL 14	2	16	6	I	B+D

The following standards / technical specifications were used:

- harmonized standards: DIN EN ISO 12100:2011-03, DIN EN 61000-6-2, DIN EN 60204

The following other EC directives were used

- 2014/30/EU
- 2014/35/EU

Essen,

26.10.2015

Datum / Date

i. V. Dr. Jürgen Timmler

Leiter Technik und Entwicklung /
Manager Engineering and Development

Machine passport

Type designation	KA-MT_____
Order no.	
Order ID.	
Build no.	
Vessel no.	
Vessel no.	
Year of manufacture	

It is the responsibility of the owner,

- to enter for the first time any appliance data not stated above,
- to keep these appliance data up to date.

The above-stated appliance data provide for a clear identification of the dryer and its components, and significantly facilitate any service measures.

Further important data on the dryer such as the details on the permissible operating pressure and the electrical connection are found on the type plate (for position of the type plate see page 11).

Table of contents

General information	7
Manufacturer's details	7
Details on the dryer.....	7
About these operating instructions	8
For your own safety	9
General safety notes.....	9
Intended use of the dryer	10
Signs and hazard areas on the dryer	11
Transportation, installation and storage	13
Information on transportation packaging	13
What to do in the case of transport damage occurring?	13
Transporting and installing the dryer	14
Storing the dryer	15
Technical product description	17
Summary drawing	17
Function description.....	17
Available options.....	20
Installation	22
Preconditions for installation	22
Connect piping.....	23
Installing the electrical connection.....	24
Start-up	26
Requirements for initial start-up	26
Setting times of the operating phases	26
Overview of operating and control elements	27
Emergency shutdown	30
Start up dryer.....	30
Changing cycle mode	32
Monitoring dryer operation	34
With dewpoint-sensing control (optional).....	34
Shutdown and restart dryer	36
Emergency shutdown	36
Depressurising and shutting down the dryer	37
If work is to be carried out on the electrical system	37
Restart.....	37

Maintenance and repair of the dryer.....	39
Notes on maintenance.....	39
Regular maintenance intervals	40
Instructions for use of the dongle.....	41
Daily maintenance tasks.....	42
Monthly maintenance tasks	43
Maintenance work to be completed every 12 months	47
Notes on further maintenance work	49
Identify and eliminate faults	51
Summary of faults	51
Index	54
Annex with technical documentation	56
Technical data.....	57
Replacement and wear parts list	58
Logic control diagram	60
Flow diagram.....	62
Dimensional drawing	63

General information

Manufacturer's details

Name and address



*Parker Hannifin Manufacturing Germany GmbH & Co. KG
Gas Separation and Filtration Division EMEA*

Im Teelbruch 118
D-45219 Essen

Phone ++49 (0) 2054 934-0
Fax ++49 (0) 2054 934-164

Internet <http://www.parker.com>

Details on the dryer

Standard equipment

Standard dryer*, consisting of

- 2 vessels, filled with desiccant
- 1 vessels, filled with purifying agent
- 1 upstream filter
- 1 downstream filter
- Piping and muffler
- Control system

Associated documents

- Operating instructions (present)
- Technical documentation (see annex)
- Circuit diagrams(separate document)
- Operating manual for installed filters (separate document)

Notes on supplementary documents

Supplementary documents such as operating manuals for options or pertaining components must always be heeded. They contain additional information, e.g. regarding maintenance, and are therefore necessary for safe operation of the plant.

* Planned dryers may be equipped with special components

About these operating instructions

These operating instructions contain basic information on the safe use of the dryer.

Characters and symbols used

- ▶ Work steps that you have to carry out in the sequence stated are marked by black triangles.
- Lists are marked by a small box.

Note:

These notes provide you with hints and information on the safe and efficient handling of machines and devices.



Warning!

These safety notes warn against damage to property and help you to avoid such damage.



Danger!

These danger notes with a grey background warn against personal injury and/or danger to life and limb; danger notes help you to avoid serious or life-threatening situations for yourself and/or third parties.

Target group of these operating instructions

These operating instructions are intended for all persons working on and using the dryer. We assume that all such persons are specialist personnel, e.g. fitters or electricians.

Operating instructions: handling

These operating instructions must be continuously available at the site where the dryer is used. We recommend to prepare a copy and to keep the same in a safe and freely accessible place next to the dryer. Keep the original document in a safe place.

For your own safety

The dryer has been built in accordance with the state of the art and the recognized technical safety regulations. Nevertheless, there is a risk of personal injury and damage to property when the dryer is used, if

- it is operated by non-qualified personnel,
- not used within its intended design specifications,
- is repaired or maintained incorrectly.

Note:

For your own safety and to prevent machine damage, please note the information and safety notes in these operating instructions when working with the dryer.

General safety notes



For your own safety, when carrying out any work on the dryer comply with all applicable national safety regulations!

Personnel qualification

Only authorized and qualified specialist personnel may be tasked with the work on the dryer described in these operating instructions.

Conversions and modifications

Without prior approval by the manufacturer, no conversions and modifications must be made to the dryer! Any non-approved modifications may restrict the operational safety of the dryer and cause damage to property or personal injury.

Handling of drying and purifying agents

The drying and purifying agents used do not pose any risk to health. However, when filling and emptying the vessels with drying and purifying agents, increased dust generation may occur. Please comply with the following instructions:

- When handling drying or purifying agents, always wear a dust mask and eye protection!
- If a spillage occurs, any spilt drying agent must be taken up immediately. There is a risk of skidding!

Disassembly and disposal



Hazard due to a sudden release of pressure!

Never remove any parts of the dryer, or manipulate the same in any way, for as long as the plant is still pressurised! A sudden escape of pressure may cause serious injuries.

Before carrying out any work on the dryer, first depressurise the plant.

- Dispose all parts of the dryer, the drying and purifying agents and all other operating materials in an environmentally safe way and in accordance with all current statutory regulations

Intended use of the dryer

The dryer is exclusively intended for drying and purifying compressed air. Depending on the defined input conditions, it dries and purifies compressed air for industrial use.

The dryer is designed for compressed air, which is free from aggressive water, oil, and solid matter constituents.

As standard, the dryer is intended to be sited within a building and protected against the weather.

The dryer may be operated only in accordance with the data on the type plate and in accordance with the contractual conditions.

Suspected misuse

The dryer must not be used as a climbing aid! Pipes, valves, and similar fittings have not been designed for such loads. They could fracture, tear off, or become damaged in another way.

Signs and hazard areas on the dryer



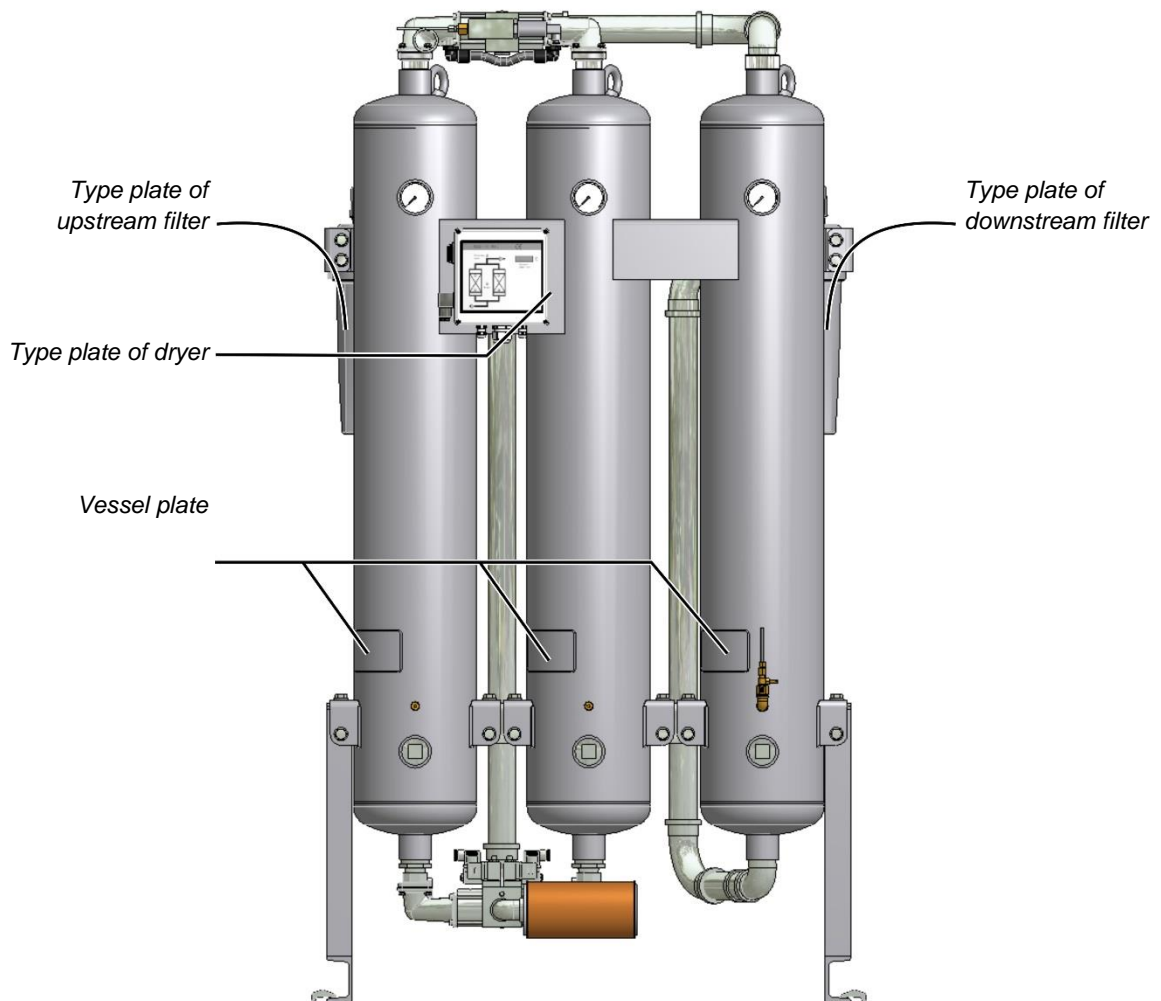



Signs and labels

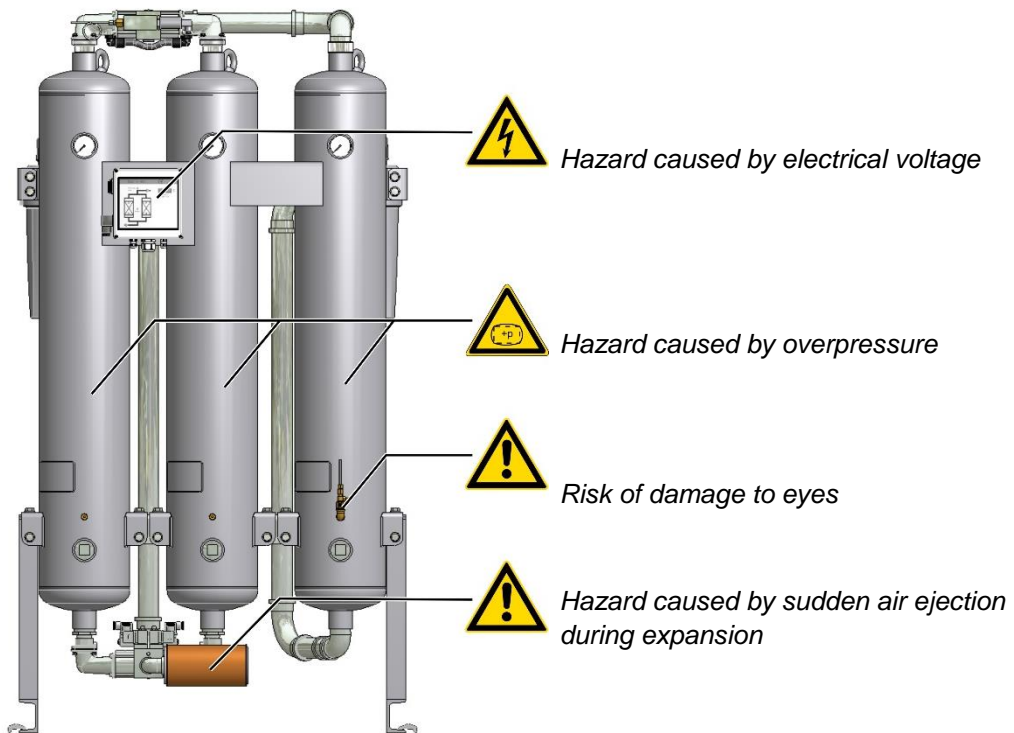

Please note these signs on the dryer. Keep them complete and always legible.

Hazard areas on the dryer



Hazard area	Symbol in operating instructions
<p>Warning against hazardous electrical voltage</p> <p>Different parts of the dryer carry electrical current. These parts may be connected, opened, and maintained by authorized specialist personnel only.</p>	
<p>Warning against overpressure</p> <p>The entire dryer is under pressure. Before commencing any work, the plant must be depressurised.</p>	
<p>Warning against sudden air ejection</p> <p>When the hollow section vessels are depressurised, air flows suddenly out of the sound absorber.</p> <ul style="list-style-type: none"> ■ This causes a sudden loud cracking noise. ■ Due to particles carried in the air flow, there is a very considerable risk of eye injury. <p>When working on the dryer, always wear eye and ear protection equipment.</p>	
<p>Risk of damage to eyes</p> <p>If not properly secured, the indicator tube might be propelled out of its holder! When the needle valve is opened, the indicator tube is secured by a union nut. If the union nut is not properly tightened, or if the oil indicator has been interfered with, there is a risk that the tube might be propelled by the air flow so that it is shot out of its holder. When working at the oil indicator, always wear protective goggles.</p>	 
<p>Risk of skidding</p> <p>When emptying and filling the hollow section vessels with drying agent, there is a risk of skidding caused by spilt drying agent.</p>	

Transportation, installation and storage



Danger due to incorrect transportation!

The dryer must be transported by authorized and qualified specialist personnel only. During transportation all applicable national regulations for accident prevention must be complied with. Otherwise there is a risk of personal injury.

Always adhere to the stickers and notes on the packaging of the dryer!

- Only use suitable and technically perfect lifting gear with a sufficient carrying capacity.
 - During transportation the dryer must be carefully secured against falling over.
- The manufacturer will not be liable for any damage caused by incorrect storage or incorrect transportation. Please note therefore the following instructions as well as the storage instructions on page 15.

Information on transportation packaging

Depending on the type of transportation, the dryer is delivered in different types of packaging:

- All transportation types: the apertures of the dryer are closed off by means of plugs.
- In addition, when transportation is effected by air: the dryer is packaged in a wooden box.
- In addition, when transportation is effected by ship: the dryer is packaged in a film material and in a wooden box.

If the packaging is undamaged

- ▶ The undamaged packaging should be removed only at the final installation site, as it offers protection against any weather influences.

What to do in the case of transport damage occurring?

- ▶ Check whether only the packaging or the dryer itself were damaged.
- ▶ Inform the haulier immediately in writing of any damages.
- ▶ Contact the manufacturer urgently in order to report the damage.



Warning!

A damaged dryer must not be taken into operation! Damaged components may lead to functional faults and possibly cause further damage.

Transporting and installing the dryer

Requirements for the installation site

The conditions at the installation site have a large influence on the functional capability of the dryer and the service life of the drying and purifying agent. In order to ensure a mode of operation, which is as continuous as possible, and low maintenance, the installation site must meet the following requirements:

- The installation site must be located within a building. Protect the dryer against moisture.
- The ambient temperature must not drop below +1,5 °C (34, 7 °F). If necessary, an auxiliary heater is to be provided.
- Heed the dryer's noise emission when selecting the installation location.
- The installation area must be level, firm and vibration-proof. It must have the necessary carrying capacity for the weight of the dryer. The weight of the dryer is specified in the technical data section of the annex.
- The dryer should be installed with sufficient spacing at the top, sides, and rear, in order to be able to carry out maintenance work and change the drying and purifying agent without any hindrances (see figure).

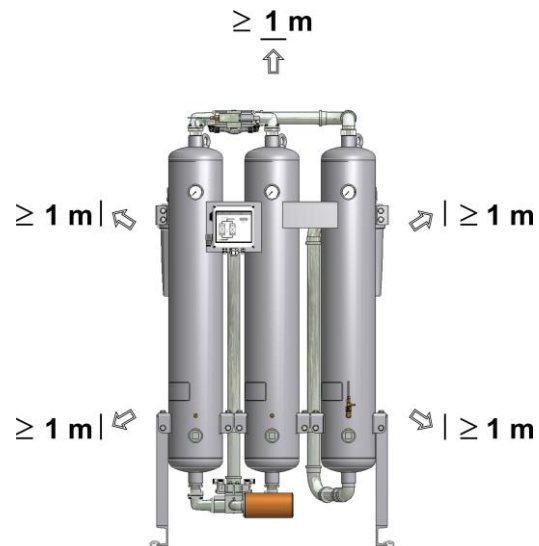

Necessary spacing at the top and sides = min. 1 m

If in doubt, the installation site must be inspected by specialists. If you have any queries in this regard, please contact the manufacturer.

Transportation using lifting or forklift trucks



Warning against damage to property!

The dryer is delivered standing on its side on a transportation pallet. Top and sides have not been designed for mechanical loads. Therefore do not place any load onto the top face. Do not stack.

Therefore, always transport the dryer on a lifting or forklift truck.

The dryer should only be transported in an upright position.

- ▶ Secure the dryer on the lifting or forklift truck against sliding movements.
- ▶ Transport the dryer to its installation site.

Installing the dryer



Caution!

Always use the lifting lugs at the top of the tank to lift the dryer. Use a lifting beam with a suitable spacing for this purpose. This will ensure the tanks cannot come in contact with the upper pipe bridge and thus damage it.

- ▶ Remove the packaging of the dryer.
- ▶ Attach suitable lifting gear to the transport lugs of the vessels (see figure I).
- ▶ Raise the dryer (see figure II) and remove the transportation pallet.
- ▶ Place the dryer at its installation site.

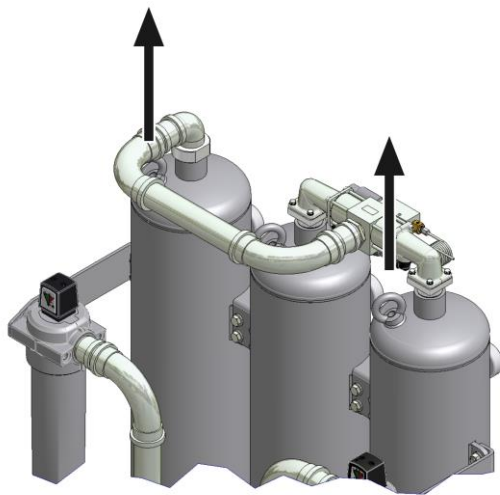

I: Transport lugs on pressure vessel

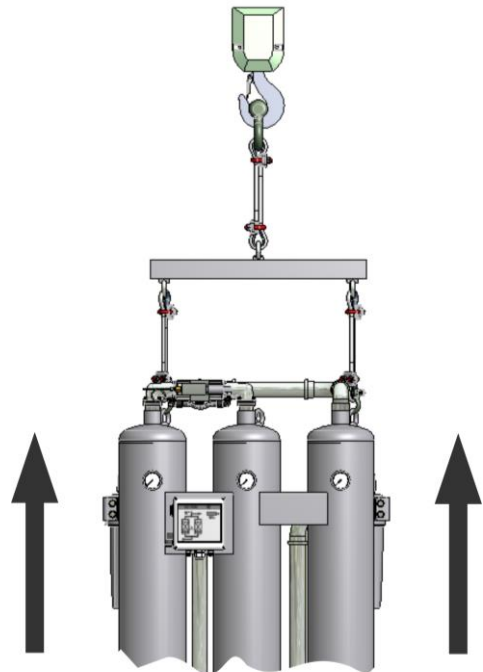

II: Installing by crane

Anchoring the dryer

- ▶ Use suitable attachment material to anchor the dryer to the floor.
- ▶ *In the case of vibrating floors:* place the dryer on suitable vibration dampers.

Storing the dryer

If the dryer is to be stored for an extended period of time, the storage location must meet the following conditions:

- The dryer must not be stored in the open air.
- The storage room must be dry.
- The storage room must be free from dust or the dryer must be covered by a protective sheet.
- The storage room must have an ambient temperature of at least +1 °C (33,8 °F).

In order to store the dryer proceed as follows:

- ▶ Take dryer out of operation as described on page 36.
- ▶ Ensure that the compressed air inlet valve installed by the owner, and the installed compressed air outlet valve installed by the owner, are both closed, and that the dryer is depressurised.
- ▶ Disconnect dryer from the compressed air system.
- ▶ Disconnect the dryer from the electrical power supply and all external lines.
- ▶ Use film material or similar to close the compressed air inlet apertures and compressed air outlet apertures on the dryer in order to protect them against contamination.
- ▶ If possible cover dryer with a protective sheet.

The dryer can now be stored for long periods.

Note:

If you wish to take the dryer back into service after an extended period of storage, please proceed as described for its first commissioning and start-up (see page 31).

Store drying and purifying agents

- ▶ Do not store drying and purifying agents in the open air.
- ▶ Protect drying and purifying agents against humidity.

Technical product description

Summary drawing

Front view

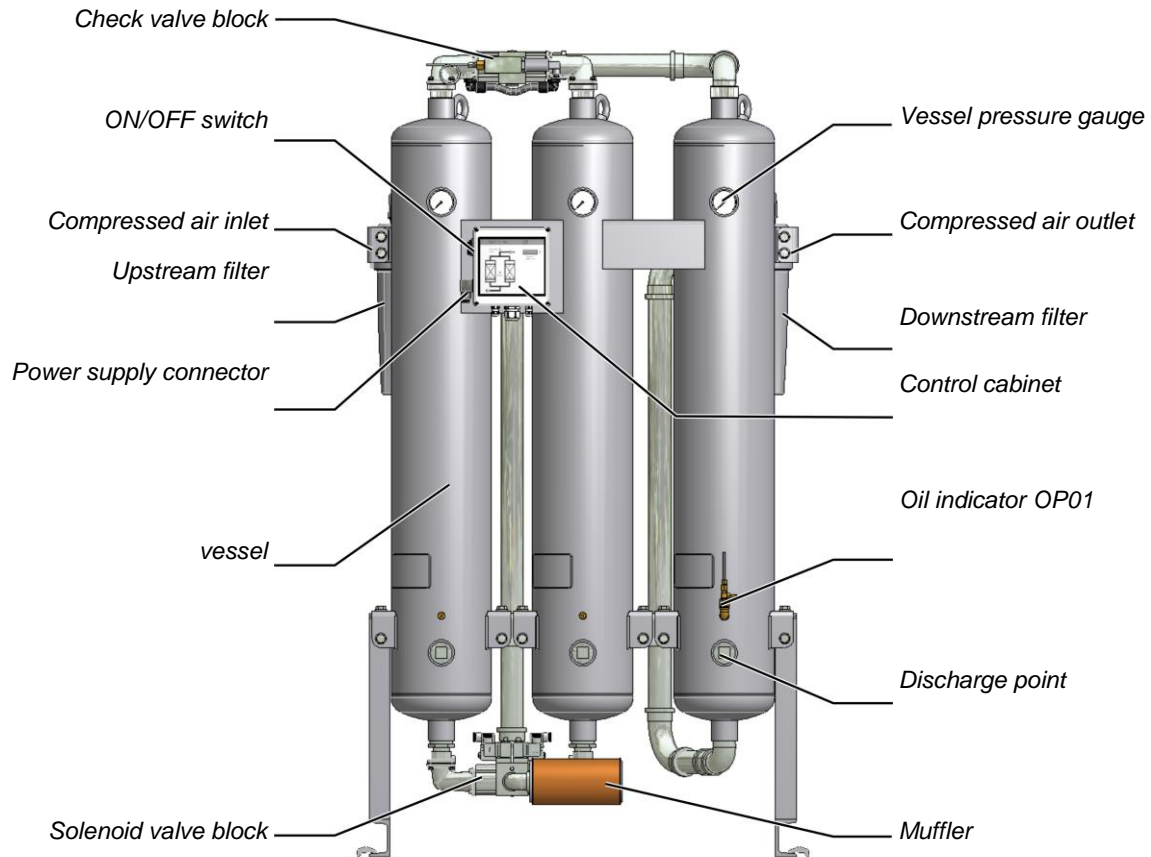

Function description

The dryer dries and purifies the compressed air supplied by the compressor and makes it available for industrial use.

The air is thereby dried alternately in one of the drying agent vessels. The dried air is subsequently purified in the third vessel, whereby oil residue and other contaminants are removed.

Before the compressed air is fed into the dryer, it flows through upstream filters where dust, dirt, oil and water droplets are removed. Thus, the installed upstream filter is also used for extending the service life of the drying agent.

The installed downstream filters clean the compressed air from drying agent abrasions, before it is fed into the compressed air system.

The two vessels contain an extremely porous drying agent by means of which humidity is removed from the compressed air and stored just as in a sponge. The stored humidity is then removed again from the drying agent and re-introduced into the ambient environment.

To this end, the two vessels alternate between different operating modes. Whilst in one vessel, compressed air is de-humidified (adsorption), in the other vessel the humid drying agent is prepared for another charge (regeneration). These two states, which run in parallel during compressed air preparation, are described below.

Adsorption

Via a compressor, humid compressed air is supplied to the upstream filter. From here, the compressed air flows upwards through the absorption vessel, which is pressurised. In so doing, the drying agent dehumidifies the air. The dried compressed air is supplied to the pipe network via the purifying vessel and the downstream filter.

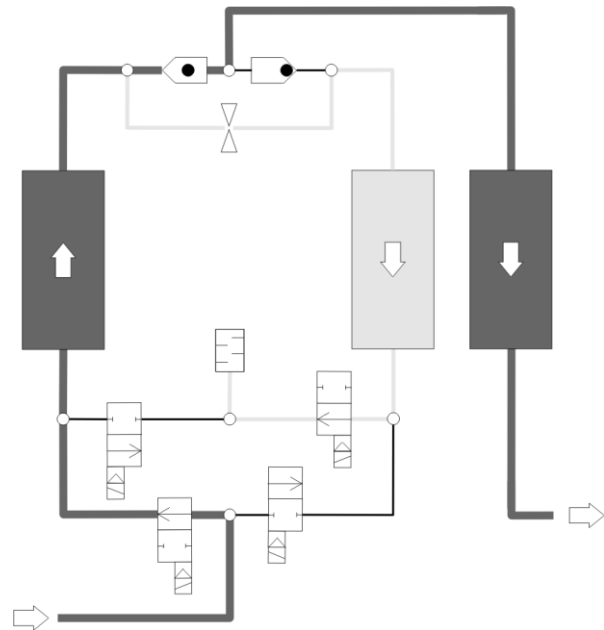

Adsorption in the left drying agent vessel.

Regeneration (running in parallel to the adsorption)

At the same time the other vessel is prepared for a renewed take-up of humidity. This process is called regeneration.

The regeneration is subdivided into three phases: expansion, dehumidification, and pressure build-up.

With the *dewpoint-sensing control* option, the regeneration phase is followed by a standby phase.

Expansion phase

During the expansion phase, the pressure in the regenerating vessel is released via the muffler down to ambient pressure within just a few seconds. The outflow of the compressed air becomes noticeable due to a sudden powerful flow noise at the muffler.

Dehumidification phase

Prior to being released into the purifying vessel, dried compressed air is bled by means of an orifice plate. This separate regeneration air flow is fed through the depressurised vessel.

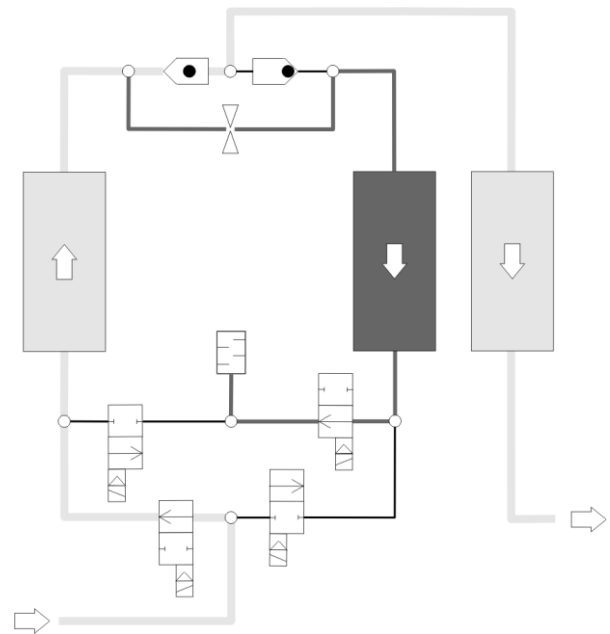

Regeneration in the right drying agent vessel

The humidity stored in the drying agent is taken up by the air flow and expelled into atmosphere via the muffler.

Pressure build-up phase

After dehumidification the pressure in the regenerated vessel is built up to operating pressure, so that the switchover from regeneration to adsorption can take place at operating pressure level.

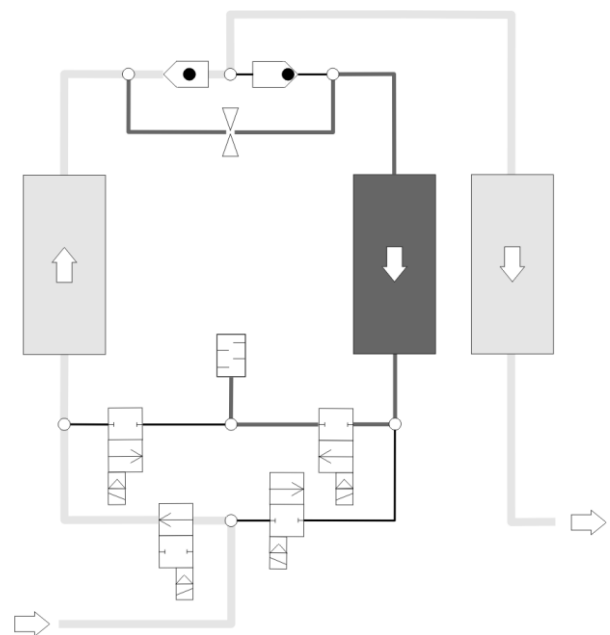

Pressure build-up in the right drying agent vessel

Standby phase (only with the dewpoint-sensing control option)

When in standby phase, the fully regenerated vessel is ready for absorption operation. The system is switched to this vessel, as soon as the measured dewpoint at the compressed air outlet has reached the set dewpoint value for switchover.

Switchover

When the drying agent in the adsorbing vessel has taken up a sufficient level of humidity, then the switchover between the vessels will be effected between the vessels. Following switchover, the above-described process is repeated, with the adsorption and regeneration now taking place in the respective different vessel.

Available options

The following options are available for the dryer:

- Start-up device
- Signalling contacts of control system
- Dewpoint-sensing control
- Fine filter muffler
- Nozzle kit

Start-up device

A start-up device basically consists of a pressure holding device, which is located at the rear of the dryer. The pressure holding device ensures that pressure can build up in the dryer and adsorption take place.

It is always required when an empty compressed air reservoir or an empty compressed air system must be filled downstream of the dryer (e.g. following weekend shutdowns and when the pressure in the compressed air system can frequently drop below the stated operating pressure).

Signalling contacts of the control system

The control system is equipped with a digital input for the synchronised operation with a compressor. This feature allows for synchronised and thus efficient dryer operation with discontinuous compressor operation.

Compressor synchronisation helps reduce energy costs, as the dryer can be operated independently of the compressor.

The compressor synchronisation controller is a higher-level controller than the pressure dew point controller (see below). When both options are in place, the compressor synchronisation controller is treated as the prime controller.

The control system can also be equipped with an optional operation signalling contact with which the dryer operation can be monitored from an external device. Dryers with the optional *dewpoint-sensing control* are equipped with such a contact as standard. It is used for the transmission of operating signals and for the output of dewpoint alarms.

Dewpoint-sensing control

With a dewpoint-sensing control system, you can operate the dryer in fixed or variable cycles. In the fixed cycle, switchover is effected after a fixed time period (usually after 5 minutes). In the variable cycle, the switchover is effected in relation to the dew point reached and the charging of the drying agent. The adsorption time in the variable cycle amounts to 60 minutes maximum.

Fine filter muffler

A fine filter muffler is used to reduce the noise emission of the dryer to lower levels than the standard muffler can provide. If installed, the fine filter muffler replaces the original installed muffler.

Nozzle kit

In the case that the operating pressure deviates from the standard design pressure (7bar_e) it is possible that the amount of necessary regeneration air changes. This effect may have a negative impact on the cost-effectiveness of the dryer. To prevent this, it is possible to replace the built in regeneration air nozzle by a nozzle with a modified bore. This replacement optimizes the regeneration air consumption and therefore restores the energy efficiency of the dryer. To receive more information on this conversion, please contact the manufacturer.

Installation



Only authorized and qualified specialist personnel may carry out work on pipes and electrical systems.

As soon as the dryer has been set up at its installation location, you can install the compressed air infeed and outlet lines and make the electrical connections.

Preconditions for installation

For a correct installation the following preconditions must be met on the part of the owner.

- Connections and lines for the infeed and outfeed of compressed air must be provided.
- A compressed air inlet valve as well as a compressed air outlet valve must be installed by the owner, so that the dryer can be installed and maintained in a depressurised condition (see also the installation example on page 23).
- All pipes, couplings, and connections must have the correct diameter and match the operating pressure.



Hazard caused by exceeding the limit values!

A safety device must be provided in order to protect against the maximum permissible operating pressure from being exceeded.

The safety device must be installed so that the dryer is reliably protected from exceeding the maximum permitted operating pressure even when the temperature of the compressed gas increases.

The data required to meet these preconditions are contained in the technical documentation attached in the annex.



Warning!

If the above preconditions are not complied with, a safe operation of the dryer cannot be assured. Also, the functionality of the dryer may be detrimentally affected.

Connect piping

In order to ensure that the dryer operates optimally, the dryer must be assembled into the compressed air system free of all stresses.

- ▶ Ensure before connection that all infeed and outfeed compressed air lines and valves are clean and undamaged.
- ▶ Check the bolt connections and retighten if necessary, as they could have worked loose during transportation.
- ▶ Remove plugs on the pressure inlet and outlet.



**All piping must be free from any stress and tension whatever!
Pipes subject to stress may burst due to the load placed on them during operation. This may cause damage to property and personal injury.**

- ▶ Use steel pipes to connect the dryer to the compressed air system.

The following figure shows an installation example.

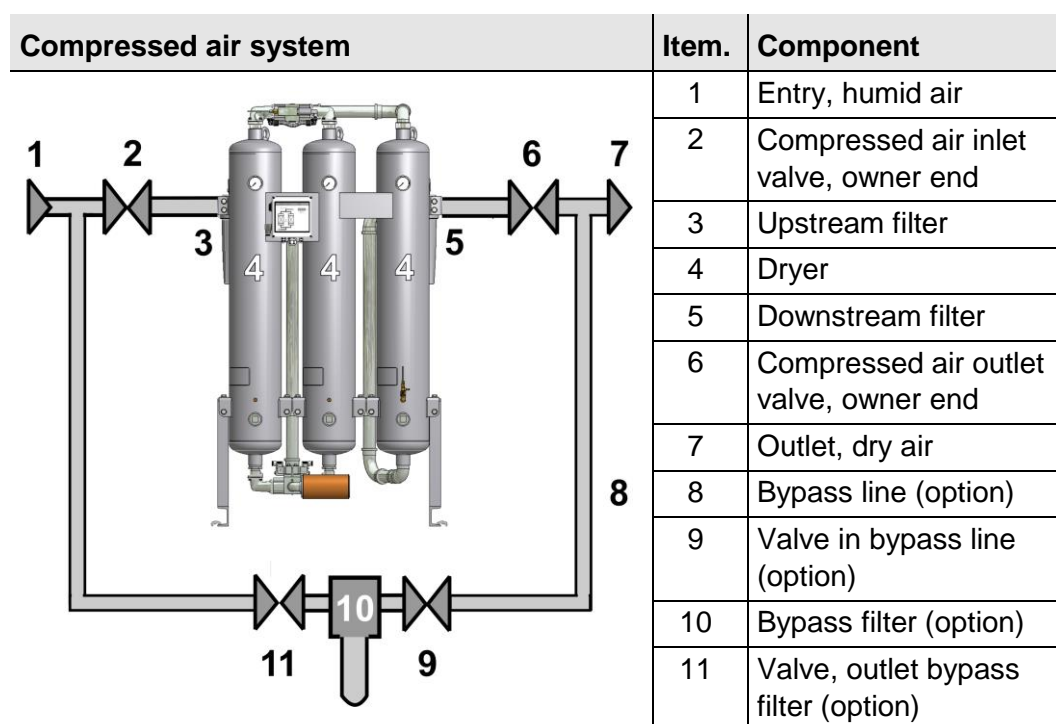

Example of an installation with bypass line

- ▶ The connection lines for the upstream filter (3) are to be installed at a slight incline in the direction of the upstream filter.
- ▶ One shutdown valve each (2, 6) is to be installed at the compressed air inlet and outlet ends of the dryer.
- ▶ *If you fit a bypass line (8) with additional shutdown valve:*
Fit the line such that, when carrying out maintenance work on the dryer, the line system can continue to be supplied with compressed air.

Installing the electrical connection



Warning against electrical voltage

Only qualified specialist personnel may carry out work on the electrical system!

Installing the supply cable

The components of the dryer have been connected to the control cabinet at the factory. You only need to connect the control cabinet to the electrical supply cable.

The switchbox is provided with a connector where electrical power must be connected.

- ▶ Ensure that the cross-section of the electrical supply cable corresponds to the power rating of the dryer and the electrical voltage provided by the customer.
- ▶ Make the electrical supply cable to the dryer voltage-free.
- ▶ Secure the electrical supply cable to the dryer against switch-on.
- ▶ Undo bolt (1) on the connector and withdraw connector with seal from the switchbox.
- ▶ Use a suitable tool to remove the terminal block from the connection box.
- ▶ Undo the PG union and pull the cable through the aperture (3). The exposed phase ends should not be longer than 35 mm max.

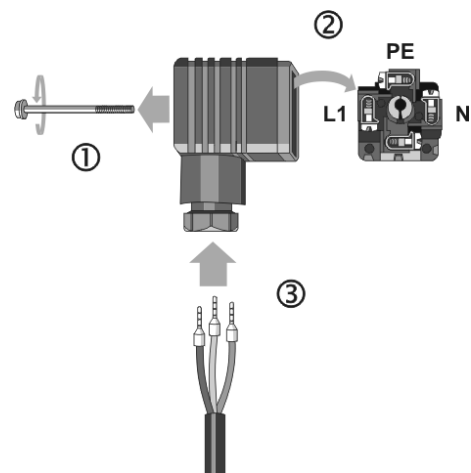

Connect electrical cable to device adapter

- ▶ Now make the cable connection as follows:
 - Earth to terminal PE
 - L1 to terminal 1
 - N to terminal 2

Terminal 3 is not used.

- ▶ Fit terminal block into the connector and use bolt to remount the connector with seal on the switchbox.
- ▶ In all phases the dryer must be protected against short circuits by means of fuses.
- ▶ In order to relief cable strain, re-tighten the PG union.

Connecting the external signalling lines

For compressor synchronisation

The controller is fitted as standard with a digital input which makes the dryer regeneration dependent on operation of the compressor (switch S1 on the controller's circuit board, see also figure below).

If switch S1 is in the ON position, operation of the compressor and dryer regeneration run synchronously: When the compressor is stopped, the dryer regeneration also stops. When the compressor is restarted, regeneration also restarts.

If switch S1 is in the OFF position, any regeneration process which has been started, is always continued until completed.

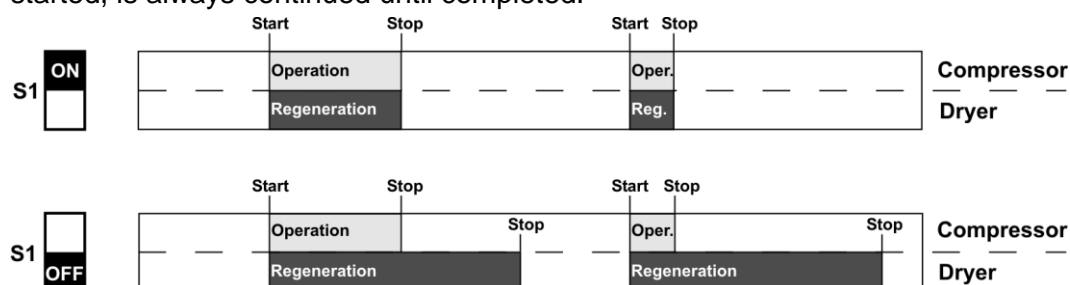

To install the external line, proceed as follows:

- ▶ Connect the signalling line to the potential-free busbar connection of the compressor to terminals 1 and 2 on the control board (see circuit diagram).

Hinweis:

The compressor synchronisation controller is a higher-level controller than the pressure dew point controller. When both options are in place, the compressor synchronisation controller is treated as the prime controller.

For operation monitoring system (optional)

Operators have the option to connect the dryer to a fault signalling system, connecting the respective line to a potential-free operation signalling contact. With this option, the following statuses and events can for example be transmitted to a remote control room:

- Dryer on (contact made)
- Power supply disconnected (no contact)
- Dewpoint alarm (only with *dewpoint-sensing control* option, no contact)

To install the external lines, proceed as follows:

- ▶ Connect the lines of the fault signalling system to relay K5 (see circuit diagram).

Check bolt connections

Before the initial start-up:

- ▶ Check all unions and bolt connections as well as the terminals in the control cabinet for secure seating; re-tighten if necessary.

Start-up

Requirements for initial start-up

For the first start-up the following preconditions must have been met:

- The pipe system is free from contaminations.
- All shutdown valves are closed.
- The dryer is correctly sited and installed.

Checks before start-up

Ensure that

- all pipe, cable and bolt connections on the dryer have been retightened,
- no pipes chafe against body edges,
- all mountings are perfectly secure,
- the needle valve of the oil indicator is closed,
- the electrical connections are in safe contact and in good condition,
- owner-end and pressurised parts such as safety valves or other devices are not blocked up by dirt or paint,
- all compressed air system parts which are pressurised (valves, hoses etc.) are free from wear symptoms and defects.

Setting times of the operating phases

In its standard version the dryer is delivered with a time-dependent control system. The phase sequence occurs in a fixed cycle.

With the optional dewpoint-sensing control, the dryer can also be operated at variable cycles (depending on the dewpoint).

The following table provides information on the duration of the individual phases.

Phase duration	Fixed cycle	Variable cycle
Adsorption	5 min	60 min, maximum
Regeneration, total	5 min	5 min
– of which: expansion time	~ 0.2 min	~ 0.2 min
– of which: dehumidification time	~ 4 min	~ 4 min
– of which: pressure build-up	~ 1 min	~ 1 min
Standby	—	~ 55 min, maximum

Overview of operating and control elements

ON/OFF switch

The ON/OFF switch (2) is located to the side of the switchbox and above the mains plug (1, see figure):

- If it is set to **0**, the power supply is disconnected and the dryer is switched off. The main valves (V1, V2) are open, while the expansion valves (V3, V4) are closed. This means that the air can circulate in the main processing direction, even if the dryer is switched off.
- If the switch is set to **I**, the dryer is switched on and begins to operate in fixed cycle mode (i.e. time-controlled).
- If the switch is set to position **II**, the dryer is switched on and begins to operate
 - with compressor synchronisation
 - in variable cycle mode (i.e. dewpoint-controlled).

Position **II** is only relevant for operation with the optional *compressor synchronisation* and/or *dewpoint-sensing control*.

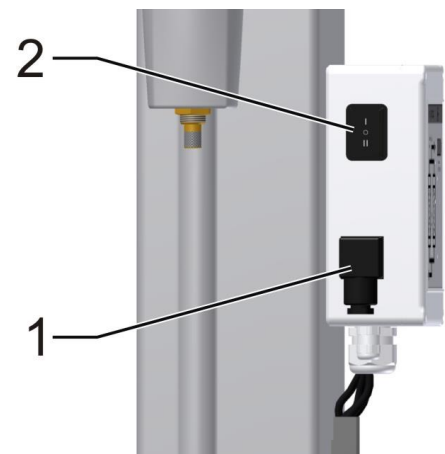

Switchbox with ON/OFF switch

Display panel

The display panel at the switchbox is equipped with LEDs (light emitting diodes) and a digital display, indicating the operating status of the dryer:

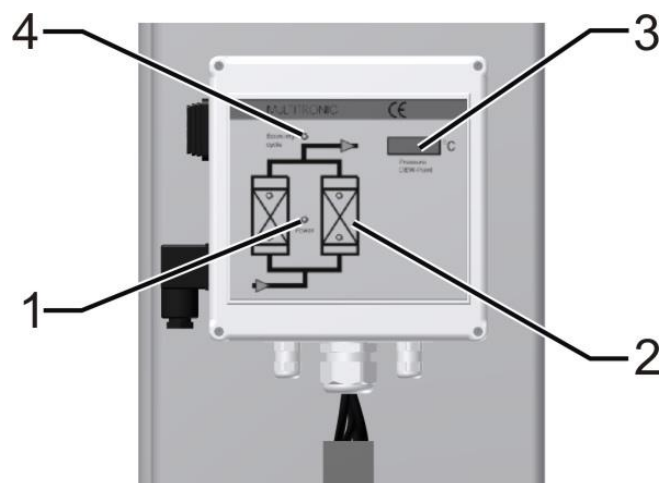

Display panel at the switchbox

LED Power (1)

LED is on when dryer is switched on.

Flow diagram (2)

The current operating phases of the dryer are indicated by means of 4 LEDs:

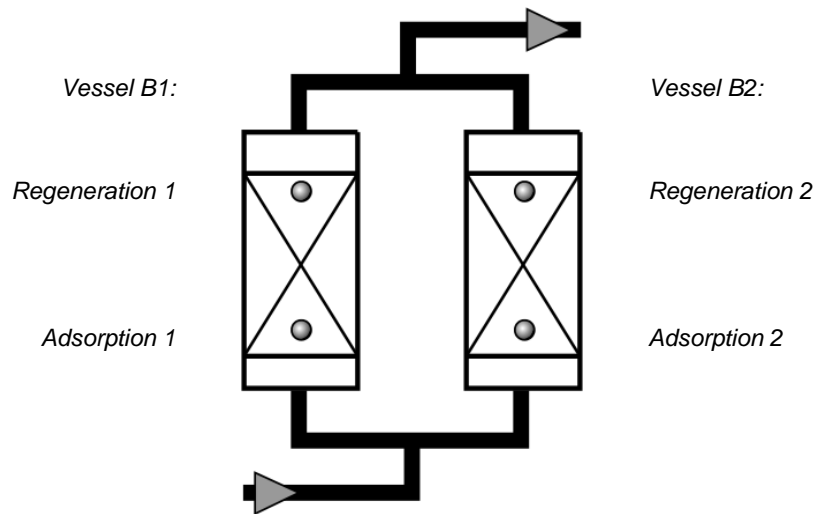

Depending on the operating phase, the following LEDs might be on simultaneously:

*Adsorption B1 and regeneration B2 or
regeneration B1 and adsorption B2.*

Digital display (3)

The digital display shows the individual programme steps and the respective remaining time. For details regarding the sequence of the individual processing steps and their duration, please refer to the logic control diagram, page 60.

Display		Explanation
2	215	Default display: The figure to the left indicates the current processing step; the figure to the right shows the remaining time in seconds. In this example, step 2 is being completed, whereby there are 215 seconds remaining.
SEr.		After 8000 operating hours, "SEr." (service) is displayed for periods of 1 minute, alternating with the default display. Notify the service personnel of the manufacturer, as a routine service is now due.
- 25		With the <i>dewpoint-sensing control</i> option, the display shows the currently measured dewpoint instead of the default data. The range of display is -100 °C (-148 °F) to +20 °C (68 °F). If the measured dewpoint exceeds the preset alarm limit (5 °C (41 °F) above the switchover value), the displayed dewpoint value is flashing.

With the optional *dewpoint-sensing control*, the following error messages might be displayed:

Display	Cause
+20	■ Upper measuring range limit exceeded
999	■ Dewpoint sensor defective
sens or -999	■ Dewpoint sensor not powered ■ Cable defective or disconnected ■ Sensor defective

LED Economy cycle (4)

This LED is only relevant in units that are equipped with the optional *dewpoint-sensing control*. The diode lights up when the dryer is switched on and in the standby phase and no regeneration air is required.

Oil indicator

The dryer is equipped with an oil indicator. The indicator allows for periodic measuring of the residual oil concentration in the purified compressed air.

The residual oil content should only be measured at set intervals, and the needle valve (1) at the indicator should be closed during normal operation.

For detailed instructions on the measuring procedure for residual oil, please refer to the respective section in the maintenance instructions, page 43.

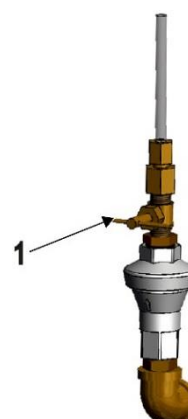

Oil indicator

Vessel pressure gauge

On both vessels, pressure gauges are fitted which show the operating overpressure. The operating overpressure indicates the operating phase of the relevant vessel:

- During adsorption the pressure gauge should indicate the nominal operating overpressure.
- During regeneration the indication of the pressure gauge on the regenerating vessel
 - should decrease in the expansion phase from operating overpressure to 0 bar overpressure,
 - indicate an overpressure of 0 bar in the dehumidification phase.

With an increasing duration of operation, a higher overpressure can be indicated during regeneration. This overpressure during regeneration is also designated as dam pressure.

- The dam pressure should not exceed 0.3 bar, otherwise read the instructions on page 42.
- During the pressure build-up phase the indication on the pressure gauge should again rise to operating overpressure level.

Emergency shutdown

To emergency shut-down the dryer heed to the following instructions:

- ▶ Close shut off valves upstream and downstream of the dryer (if applicable)
- ▶ Disconnect the electrical power supply (i.e. by switching the **ON/Off** switch to **0**).
- The dryer is now off-line.
- ▶ If applicable, depressurise the dryer now.

Before re-commissioning the dryer ensure that the emergency situation has been solved and that the dryer is not damaged.

Never commission a damaged dryer!

Start up dryer



Warning against sudden air ejection!

During expansion the pressure is released suddenly through the muffler:

- A loud expansion noise is caused which may damage your hearing.
- Particles carried in the air can injure your eyes or skin.

Always wear eye and ear protection, therefore, when you are in the vicinity of the dryer!



Hazard due to a sudden release of pressure!

Never remove any parts of the dryer, or manipulate the same in any way, for as long as the plant is still pressurised! A sudden escape of pressure may cause serious injuries.

Before carrying out any work on the dryer, first depressurise the plant.

- Carry out all prescribed tests and checks.
- The factory settings on the control board in the switchbox must not be changed on any account without prior approval by the manufacturer.
- Before start-up, ensure that no tools or other foreign parts have been left lying in a part of the dryer where they might pose a hazard to the dryer being started up

Open compressed air supply and switch on dryer

For start-up, please proceed in the sequence shown here.

- ▶ Ensure that the compressed air inlet and outlet valves installed by the owner are closed (see installation example on page 23).
- ▶ Ensure that the compressed air system upstream of the dryer is pressurised. If necessary, pressurise (switch on compressor).



Slowly open compressed air inlet valve!

Avoid sudden pressure build-up in any circumstance! If pressure builds up too fast, this may cause damage to the dryer. Therefore, the compressed air inlet valve must always be opened quite slowly!

- ▶ Slowly open the compressed air inlet valve, installed by the owner, upstream of the dryer.
- ▶ Switch on dryer: to this end, set the ON/OFF switch to I.

If the dryer is taken into operation for the first time, or after a change of drying agent, the following intermediate step is meaningful. In the case of a restart situation, the following intermediate step can be skipped.

Operating the dryer for the first time (or after a change of drying agent) separately

Depending on the transportation and storage conditions, the drying agent in the vessels can already be loaded with humidity from the environment. At each first start-up it makes sense therefore to operate the dryer from some time separately from the compressed air system. This causes the drying agent in each vessel to be regenerated repeatedly and thus to be prepared optimally for the take-up of humidity.

Note:

Depending on the pressure dew point to be achieved, we recommend to operate the dryer at first start-up without compressed air consumption:

- for at least 4 hours at a pressure dew point of -25 to -40 °C or
- for approx. 3 to 5 days at a pressure dew point of -70 °C.

If you wish to take the dryer into operation in accordance with our recommendation, proceed as follows:

- ▶ Ensure that the compressed air outlet valve installed by the owner is closed.
- ▶ Keep the compressed air outlet valve closed for the time period recommended above.

Then the dryer can be taken into service in the compressed air system as described in the following section:

Operate dryer immediately in the compressed air system

- ▶ Ensure that the compressed air system downstream of the dryer is pressurised or that a start-up device (option, see page 20) was installed into the compressed air system directly downstream of the dryer.
The importance of this increases with the size of the compressed air system downstream of the dryer. Smaller compressed air systems can be pressurised also by means of compressed air fed through the dryer.



Slowly open compressed air outlet valve!

Avoid a sudden drop in pressure in any circumstance! If pressure drops too fast, this may cause damage to the dryer. Therefore, the compressed air outlet valve must always be opened quite slowly!

- ▶ Slowly open the compressed air outlet valve installed by the owner. Observe the vessel pressure gauge of the pressurised vessel. The pressure should not drop below the operating pressure (if poss.). If necessary, keep the compressed air outlet valve in a slightly open position until the compressed air system downstream of the dryer has filled up completely; only then should the valve be opened fully.

Then the dryer has to be taken into operation within the compressed air system.

In the event of a fault

In the event of an emergency or if a safety-relevant disruption occurs (e.g. escaping compressed air, defective component), the dryer must be shut down immediately as described in the section on page 36).

Then proceed as follows:

Remedy fault

- ▶ Look up possible cause of the fault, and how to remedy the same, in the table on page 51.
- ▶ Remedy fault.
- ▶ Repeat the start-up procedure.

Changing cycle mode

When can I change cycle mode?

If the dryer has been successfully commissioned and is equipped with one of the following options:

- *compressor synchronisation* or
- *dewpoint-sensing control*

it can be set to *economy cycle mode*.

When should I change cycle mode?

Cycle changes should be made during the pressure build-up phase and prior to switchover; during this phase, the pressure in both chambers is just below operating pressure so that a fast pressure build-up is prevented when the chambers are switched.

During this period, only the adsorption LED is on in the diagram, and the digital display shows step 4 or step 9 for the duration of 1 minute (see logic control diagram; not displayed with dewpoint sensing).

Which cycle modes can I choose?

If the dryer is connected to a *compressor synchronisation system* and is equipped with the *dewpoint-sensing control* option, these two optional devices can only be started together. The compressor synchronisation has thereby precedence over the dewpoint-sensing control.

With compressor synchronisation

If compressor synchronisation is enabled, the dryer can only be operated in conjunction with the compressor. As soon as the compressor is switched off, the dryer is automatically set to standby mode.

In standby mode, the control system remains on, and the dryer is ready for the next switchover, which is made as soon as the compressor is switched on.

Note:

The compressor synchronisation controller is a higher-level controller than the pressure dew point controller. When both options are in place, the compressor synchronisation controller is treated as the prime controller.

With dewpoint-sensing control

Dryers equipped with dewpoint-sensing control operated in variable cycle mode, based on the measured dewpoint of the dried air at the compressed air outlet. As soon as a certain dewpoint is reached, as the drying agent in the absorbing chamber is saturated, the chambers are switched.

The dewpoint at which a switchover is made is preset at the factory.

How do I change cycle mode?

- ▶ Wait until the dryer has reached the pressure build-up phase (phase prior to switchover).

One LED for *Adsorption B1/B2* is on in the flow diagram.

- ▶ Set the ON/OFF switch to position **II**.

The programme continues the cycle.

Monitoring dryer operation

The dryer operates fully automatically. However, you should carry out the regular checks described in the Chapter *Maintenance and repair of the dryer*.



Warning against sudden air ejection!

During expansion the pressure is released suddenly through the muffler:

- **A loud expansion noise is caused which may damage your hearing.**
- **Particles carried in the air can injure your eyes or skin.**

Always wear eye and ear protection, therefore, when you are in the vicinity of the dryer!

- The more powerful the dryer is, the more noise may be generated during operation. Therefore, the operator must provide suitable protective equipment (e. g. ear protection).
- Only operate the dryer within the permissible limits. By operating the dryer in conditions for which it has not been designed, functional faults may be caused.
- Depending on the size of the dryer and the compressed air network and the respective legal requirements in your country, it may be necessary to perform initialisation according to the directive for pressure equipment.
- Check the dryer regularly for externally visible damage and defects. Any changes, even in its operating behaviour, must be reported immediately to the competent office or person.
- In the event of an emergency or if a safety-relevant disruption occurs (e.g. escaping compressed air, defective component), the dryer must be shut down immediately as described in the section on page 36). The unit may only be restarted after all defects have been eliminated.

With dewpoint-sensing control (optional)

Display of dewpoint

If the dryer is equipped with a dewpoint-sensing control system, the digital display at the front of the switchbox shows the currently measured dewpoint. The range of display is -100 °C (-148 °F) to $+20\text{ °C}$ (68 °F).

If the set dewpoint is exceeded, the system automatically completes a switchover between the vessels. The dewpoint at which a switchover is made is preset at the factory.

- ▶ After commissioning or extensive maintenance work, check the dewpoint display at the dryer.

Under certain circumstances, the desired dewpoint is only reached after prolonged operation.

Error messages

If the measured dewpoint exceeds the preset alarm limit (5 °C (41 °F) above the switchover value), the displayed dewpoint value is flashing. In addition, an error message can be issued through the potential-free busbar.

Error codes and their causes:

Display	Cause
+20	■ Upper measuring range limit exceeded
999	■ Dewpoint sensor defective
sens or -999	■ Dewpoint sensor not powered ■ Cable defective ■ Sensor defective

For instructions on how to eliminate faults, see chapter *Identify and eliminate faults*

Shutdown and restart dryer

In the following cases, the dryer must be fully shut down and depressurised:

- In the event of an emergency or malfunction
- For maintenance work
- For dismantling



Caution!

Risk of damage to the dryer, if it is switched off during the expansion or drying phase.

During these phases, the pressure in the regenerating chamber is released to ambient pressure: If the main valve is opened, as the dryer is switched off, there is a sudden pressure build-up in the chamber. This might result in

- damage to the drying agent, and
- excessive abrasion, with negative impact on the regeneration capacity.

Before switching off the dryer, wait until it has reached the pressure build-up phase or is in standby mode (before switchover).

Note:

If the unit is equipped with a compressor synchronisation system, first switch off the compressor and then wait until the dryer has reached the standby phase before switching it off with the ON/OFF switch.

This ensures that the regeneration cycle is completed, and that the pressure in both chambers is at the same level.

As soon as the dryer is switched on again, the programme continues the cycle from the point at which it has been stopped.

Emergency shutdown

To emergency shut-down the dryer heed to the following instructions:

- ▶ Close shut off valves upstream and downstream of the dryer (if applicable)
- ▶ Disconnect the electrical power supply (i.e. by switching the On/Off switch to **0**).
- The dryer is now off-line.
- ▶ If applicable, depressurise the dryer now.

Before re-commissioning of the dryer ensure that the emergency situation has been solved and that the dryer is not damaged.

Never commission a damaged dryer!

Depressurising and shutting down the dryer

Close compressed air feed line

- ▶ Close the compressed air inlet valve (provided by the operator).

Disconnect voltage supply

- ▶ Switch off the dryer by setting the ON/OFF switch to position **0**.

Disconnect dryer from compressed air system

- ▶ Close the compressed air outlet valve installed by the owner.
- ▶ If available, open bypass line.

Depressurise dryer

- ▶ Depressurise dryer, e.g. by opening the manual drain at the downstream filter.

If work is to be carried out on the electrical system

- ▶ Depressurise and shut down the dryer, following the instructions in the above chapter.



Risk of injury due to voltage-carrying parts!

The electrical supply cable and external power lines are live even after the dryer is switched off and, in the event of body contact, may cause serious injury! Before carrying out any work on the electrical system, the electrical supply cable and all external power lines must be made voltage-free!

- ▶ Make the electrical supply cable to the dryer voltage-free.
- ▶ Secure the electrical supply cable to the dryer against switch-on.

Restart

Depending on the fittings installed by the operator and the actual pressure conditions, the unit might have to be restarted at operating pressure. The following general rules apply:

- When switched off, the dryer is open in main flow direction. With the optional *start-up device*, the set minimum pressure must however be reached prior to restart.
- If the dryer is equipped with a dewpoint-sensing control system, it is depressurised gradually, according to the read measuring current.

If compressed air system and dryer have remained at operating pressure

- ▶ Ensure that the compressed air inlet valve (provided by the operator) is open.
- ▶ Set ON/OFF switch to **I**. The programme continues the cycle from the point at which it was interrupted.



Slowly open compressed air outlet valve!

Avoid a sudden drop in pressure in any circumstance! If pressure drops too fast, this may cause damage to the dryer. Therefore, the compressed air outlet valve must always be opened quite slowly!

- ▶ Slowly open the compressed air outlet valve installed by the owner. The pressure should not drop below the operating pressure (if poss.). If necessary, keep the compressed air outlet valve in a slightly open position until the compressed air system downstream of the dryer has filled up completely; only then should the valve be opened fully.
- ▶ If available, block off bypass line.

The dryer is now in operation again and operates fully automatically.

If compressed air system and dryer have not remained at operating pressure

- ▶ If disconnected, reconnect the voltage supply of the dryer.
- ▶ Pressurise and switch on the dryer as described in the section *Open compressed air supply and switch on dryer* on page 31.

The dryer is now in operation again and operates fully automatically.

After the purifying agent has been replaced

The newly filled purifying agent contains minute dust particles that can block the downstream filters. We therefore recommend to complete the following steps before you restart the dryer, in order to protect your equipment:

- ▶ Remove the housing base and the filter element from the downstream filter.



Wear eye protection and dust mask due to increased dust generation!

If the dryer is operated without downstream filter, there is a risk of increased dust generation.



In order to avoid any eye irritations, wear protective goggles!

In order to avoid any dust inhalation, wear dust mask!

Restart the dryer:

- ▶ Switch on the dryer and pressurise as described in section *Open compressed air supply and switch on dryer*, page 31.

The compressed outlet valve must be closed and the downstream filter housing must be open:

- ▶ Operate the dryer for approx. thirty minutes, blowing the dust particles off from the downstream filter.

Shut down the dryer:

- ▶ Close the compressed air inlet valve installed by the owner.
- ▶ Switch off the dryer by setting the ON/OFF switch to position 0.

Reassemble the filter and commission the dryer (see the operating manual of the filter for the reassembly).

- ▶ Switch on the dryer and pressurise as described in section *Open compressed air supply and switch on dryer*, page 31.
- ▶ Check that the vessel and the downstream filter are leak tight.

Maintenance and repair of the dryer

In order to allow maintenance work on the dryer to be carried out efficiently and without danger for maintenance personnel, you should comply with the following instructions.

Notes on maintenance



Danger!

There is a very considerable risk of personal injury, when carrying out work on the activated and pressurised dryer.



Before commencing any maintenance tasks always shut down the dryer as described on page 36, !



Warning!

Maintenance tasks may be carried out only by authorized and qualified specialist personnel, and only with the plant in a switched off and depressurised condition.

Note:

In order to ensure perfect maintenance and reliable operation we recommend that you conclude a maintenance contract.

When exchange or replacement parts are ordered, always state the dryer type and the build no. of the dryer. These data are found on the type plate.

- Carry out all maintenance work only when the plant has been shut down and depressurised!
- Bolt connections must be undone with care! Note ram pressure values! Otherwise emerging media may cause personal injury.
- Do not modify the factory settings of the control system in any way without prior consultation with the manufacturer.
- Never carry out any manipulations on a hollow profile vessel or modify the same in any way!
- Following maintenance work, always check all flange and bolt connections for leakage and secure seating.
- Never use pipes and fittings as steps or holding points! The components might fracture, or the distortions which occur may cause internal damage on the dryer. There is a risk of injury by slipping off the components, components breaking off, and expanding compressed air!
- Never leave tools, loose parts or cloths at or on the dryer.
- Only use replacement parts that are suitable for the relevant function and meet the technical requirements stipulated by the manufacturer. This is always the case, if you use original replacement parts only.

Regular maintenance intervals

Note:

If a vessel has been depressurised, e.g. after completion of the expansion phase, and the pressure remains above 0 bar, the vessel is pressurised by what is known as ram pressure. This might be due to

- blockage at the muffler(s),
- contamination of the dust sieves,
- spent drying and purifying agent.

To prevent such malfunctions, regularly service the dryer as described below.

The table provides an overview of the maintenance work to be carried out. The following pages describe some of these tasks. Maintenance work requiring the dryer to be largely disassembled is not described. We recommend to have this work to be performed by authorised specialists.

Component	Maintenance task to be carried	Maintenance interval					see page
		daily	monthly	12 months	24 months	48 months	
Complete dryer	Carry out visual and function checks.	●					42
Vessel pressure gauge	Check dam pressure. For a dam pressure exceeding 0.3 bar: – Check muffler. – Check dust sieve. – Check drying agent.	●					42
Oil indicator	Measure the residual oil content and the residual capacity of the purifying agent.		●				43
Muffler	Replace muffler after 1 year of operation and after renewing the desiccant.			●		●	47
fine filter muffler	Replace element of fine filter muffler after 1 year of operation and after renewing the drying agent.			●		●	47
Dew point sensor (with optional dew point sensing-control)	Renew			●			48
Purifying agent	Renew. If the fed compressed air is humid, the maintenance interval is reduced to 6 months.			●			49
Pilot valves	Renew.			●			49
Main valves V1/V2	Renew.				●		49
Expansion valve V3/V4	Renew.				●		49
Check valves V5/V6*	Renew.				●		49
Solenoids	Renew.				●		49

Component	Maintenance task to be carried	Maintenance interval					
		daily	monthly	12 months	24 months	48 months	see page
drying agent	Renew.					●	50
Upstream and downstream filters	Please see the enclosed operating instructions for the attached filters. Maintenance work has to be carried out as specified in this document						

When carrying out any maintenance work, comply with the following safety instructions:



Danger!

There is a very considerable risk of personal injury, when carrying out work on the activated and pressurised dryer.

Before commencing any maintenance tasks always shut down the dryer as described on page 36, !



Warning against electrical voltage!

Only qualified specialist personnel may carry out work on the electrical system!



Instructions for use of the dongle

If the message **SEr.** is displayed on the display of the Multitronic controller, the dryer is due for servicing. The message appears, flashing every 60 seconds, once the preset number of operating hours (e. g. 8000 oh) has been reached. After maintenance has been carried out, you can use the dongle to reset the counter to 0 and delete the message from the display. A dongle is enclosed with every service kit. Each dongle can only be used once.

- ▶ Switch off the controller. Caution! The electric line is still live. Do not touch live parts!
- ▶ Open the lid to the Multitronic controller. The circuit board is housed underneath it.
- ▶ Slot the dongle into the dongle interface *X9 PC*.
- ▶ Press and hold the reset key *S3*.
- ▶ Switch on the controller. The following appears in the display:

for a short time then flashing	0.SET OFF
-----------------------------------	----------------------------

The service counter is then reset to 0.

If the following appears in the display:

for a short time then flashing	FAIL OFF
-----------------------------------	---------------------------

this means that the dongle has already been used once and cannot be used again.

- ▶ Switch off the controller again and remove the dongle.
- ▶ Dispose of the unusable dongle and use a new one.

Daily maintenance tasks

Carry out visual and function check on the complete dryer

- ▶ Check dryer for external damage or unusual noise generation.
- ▶ Duly eliminate any defects found.

If message **SEr.** is displayed, a routine service must be completed:

- ▶ Contact the service department of the manufacturer.

Clean dryer

- ▶ Remove any loose dust by means of a dry cloth, and, if required, also by means of a moist and well wrung cloth.
- ▶ Clean the surfaces with a moist well wrung cloth.

Check dam pressure

If, following depressurisation of a vessel, e.g. after the expansion phase, the overpressure has not decreased to 0 bar, then there is a residual pressure, designated as dam pressure, in the vessel.

- ▶ Check for dam pressure: if the dryer functions correctly, the respective pressure gauge indicates 0 bar. Then there is no dam pressure.

If the dam pressure is greater than 0.3 bar:

- ▶ Depressurise the dryer and shut it down (see page 36).

Dam pressure can be caused by:

- a blocked muffler,
- a blocked dust sieve or
- drying and purifying agent which is too old.

The respective necessary maintenance measures are described in the following sections.

Monthly maintenance tasks

Measuring of residual oil content

The dryer is equipped with an oil indicator. The indicator allows for periodic measuring of the residual oil concentration in the purified air.

It is recommended to measure the residual oil content every month, using the oil indicator; this allows the operator to determine the absolute residual oil content in the air and the available capacity of the purifying agent.

The measuring principle is as follows: For the duration of the measurement, the needle valve (1) is opened so that a pressure-reduced partial flow of purified compressed air is fed through the indicator tube (2). The indicator tube is secured by means of a union nut (3).

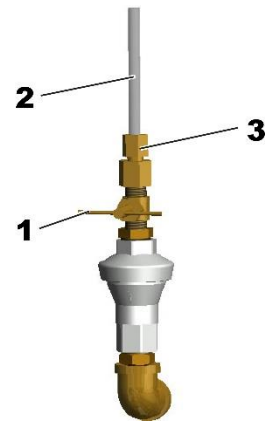

Oil indicator

Any residual oil contained in the air leads to a change of colour of the scale segments of the tube, whereby a higher concentration leads to more segments being coloured.

The change of colour is irreversible; after completion of the measurement, the indicator tube must thus be replaced. It is therefore useful to close the needle valve between measurements.

To measure the residual oil concentration, proceed as described below. A template of the measuring log used for this procedure is included in the appendix.



Risk of damage to eyes! If not properly secured, the indicator tube might be propelled out of its holder!

When the needle valve is opened, the indicator tube is secured by a union nut. If

- the union nut is not properly tightened, or
- if the oil indicator has been interfered with,

there is a risk that the tube might be propelled by the air flow so that it is shot out of its holder.

When working at the oil indicator, always wear protective goggles.

Prior to opening the needle valve, check that the union nut at the indicator tube is properly tightened.

Measuring procedure

- ▶ Prepare measuring log and hold it ready.
- ▶ Check union nut holding the indicator tube and retighten, if necessary.
- ▶ At the indicator tube, mark the highest segment with a colour change, using a suitable pen.
- ▶ Open needle valve by turning its handle anticlockwise. Write down start date and time of the measurement.

- ▶ Leave needle valve open for the desired duration of measurement (e.g. 5 hours).
- ▶ Subsequently, close the needle valve. Write down end time of measurement.
- ▶ At the indicator tube, mark the highest segment with a colour change, using a suitable pen. Write down the number of scale segments that have changed colour since the start of the measurement.

Evaluation of measurement: determining the absolute residual oil content

To evaluate the test results, please refer to the table below:

Duration [h]	Number of first-ever coloured scale units							
	0.2	0.4	0.6	0.8	1.0	1.2	1.4	1.6
4	0.58	1.15	1.70	2.25	2.80	3.40	3.95	4.40
4.5	0.55	0.95	1.45	1.90	2.45	2.85	3.55	3.95
5	0.45	0.86	1.35	1.79	2.25	2.70	3.20	3.65
5.5	0.43	0.81	1.17	1.65	2.00	2.40	2.85	3.35
6	0.40	0.78	1.15	1.45	1.79	2.25	2.60	2.85
6.5	0.35	0.72	1.12	1.35	1.70	2.20	2.35	2.75
7	0.32	0.62	0.95	1.17	1.60	1.90	2.25	2.58
8.5	0.27	0.58	0.87	1.15	1.20	1.55	1.85	2.10
10	0.22	0.45	0.65	0.95	1.15	1.35	1.55	1.85
12.5	0.18	0.37	0.57	0.70	0.85	1.08	1.25	1.45
16.5	0.13	0.27	0.45	0.57	0.65	0.80	0.90	1.08
25	0.09	0.18	0.30	0.38	0.45	0.60	0.65	0.75
33	0.07	0.12	0.19	0.30	0.32	0.42	0.50	0.55
50	0.045	0.090	0.130	0.180	0.225	0.300	0.350	0.400
56	0.040	0.080	0.110	0.155	0.195	0.275	0.300	0.350
63	0.036	0.070	0.105	0.145	0.180	0.225	0.275	0.300
72	0.032	0.062	0.095	0.128	0.155	0.190	0.245	0.275
84	0.025	0.052	0.085	0.105	0.130	0.155	0.180	0.225
100	0.020	0.042	0.068	0.088	0.110	0.135	0.155	0.180
125	0.015	0.035	0.053	0.075	0.088	0.108	0.130	0.145
166	0.008	0.028	0.040	0.055	0.068	0.085	0.095	0.108
250	0.006	0.015	0.025	0.037	0.045	0.055	0.065	0.070
500	0.002	0.007	0.012	0.018	0.02	0.025	0.032	0.035
1000	0.001	0.003	0.005	0.007	0.008	0.012	0.014	0.018

Table for the determination of the residual oil content in [ppm] at 7 bar operating pressure

Note:

The evaluation is based on a pressure-reduced partial flow that is fed into the indicator tube at a pressure of 7 bar operating pressure. For dryers with an operating pressure of less than 7 bar, please refer to the respective table in the appendix (for 4, 5 or 6 bar operating pressure).

- Determine the concentration in the above table, based on the duration of the measurement and the number of scale segments with colour change.

<i>Example</i>	
Duration of measurement in [h]	5.0
Number of scale segment with colour change	1.0
Residual oil concentration in [ppm]	2.25

- Write down the residual oil concentration in ppm, parts per million] in the measuring log.
- To determine the residual oil content in [mg/m³], multiply the above value by a factor 1.2. Write down this value in the measuring log.

Determining capacity reduction of purifying agent

To establish the remaining capacity of the purifying agent, you must carry out measurements of the same duration at fixed intervals.

- Choose a measuring interval (e.g. 4 weeks) and a duration of measurement (e.g. 4 hours).
- Determine the maximum admissible residual oil concentration in [mg/m³] for your specific application. Divide this value by 1.2 in order to obtain the maximum admissible residual oil concentration in [ppm].
- Refer to the table on page 44 and determine the corresponding number of scale segments with colour change.

<i>Example</i>	
Maximum admissible residual oil concentration in [mg/m ³]	3.4
Maximum admissible residual oil concentration in [ppm]	2.83
Duration of measurement in [h]	4.0
Maximum admissible number of scale segments with colour change (across entire measuring sequence)	1.0

If there are no additional segments with colour change at the end of the measuring procedure, the purifying agent is working at full capacity.

As its capacity is reduced over time, the number of scale segments with colour change in the tube is increased.

If the established maximum admissible number of segments with colour change is reached, the purifying agent must be replaced (see also page 49).

If all scale segments in the indicator tube show a colour change, the indicator tube is spent and must be replaced as described below.

Replacing indicator tube



Risk of damage to eyes! If not properly secured, the indicator tube might be propelled out of its holder!

When the needle valve is opened, the indicator tube is secured by a union nut. If

- the union nut is not properly tightened, or
- if the oil indicator has been interfered with,

there is a risk that the tube is propelled by the air flow so that it is shot out of its holder.

When working at the oil indicator, always wear protective goggles.

Prior to removing the indicator tube, ensure that the needle valve is closed and that the tube is not under pressure!

The colour change of the tube segments (2) is irreversible. When all segments have changed colour, the indicator tube must be replaced.

Prior to removing the tube:

- ▶ Ensure that the needle valve (1) is closed and that the indicator tube (2) is not under pressure. To close the needle valve, turn its handle clockwise.

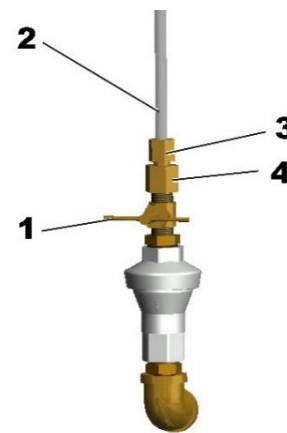

Oil indicator

To remove the indicator tube:

- ▶ Loosen the reducer (4) below the union nut (3), using an appropriate tool.
- ▶ Dispose of spent indicator tube and reducer according to the application regulations.

To install new indicator tube:

- ▶ Screw indicator tube into the reducer, applying a non-locking thread seal.
- ▶ Check the union nut (3) and the reducer (4) to ensure that they are properly tightened.

To check tube:

- ▶ Open the needle valve (1) for a short time and check screw connections for tightness.

Maintenance work to be completed every 12 months

Renew muffler

The dryer is equipped with a muffler. If the muffler becomes blocked, a dam pressure is generated which in extreme cases may cause the muffler to burst.



Hazard caused by blocked muffler!

Blocked mufflers can cause a dangerous overpressure to build up which may cause the mufflers to burst. Flying fragments may cause personal injury and damage to property.

Therefore, the mufflers must be replaced every 12 months and after each change of desiccant.



Warning against sudden air ejection!

During expansion the pressure is released suddenly through the muffler:

- A loud cracking noise occurs which can injure your hearing.
- Particles carried in the air flow act like bullets and can injure your eyes or skin.

Always wear eye and ear protection, therefore, when you are in the vicinity of the dryer!

- ▶ Depressurise the dryer and shut it down (see page 36).
- ▶ Unscrew muffler as shown in the opposite figure.
- ▶ Replace muffler and secure it.
- ▶ Restart dryer (see page 38).

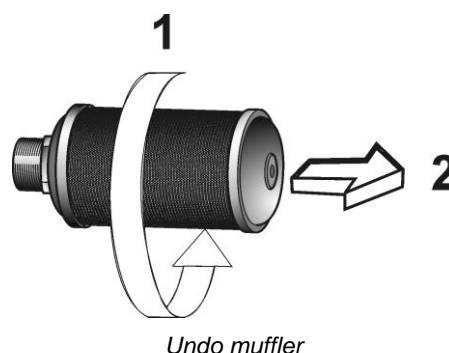

Replace the element in the fine filter muffler

- ▶ Depressurise the dryer and shut it down (see page 36).
- ▶ Undo knurled screw on the lid cap and remove cap.
- ▶ Unscrew old filter element. Arrows on the element bottom mark the direction of rotation.

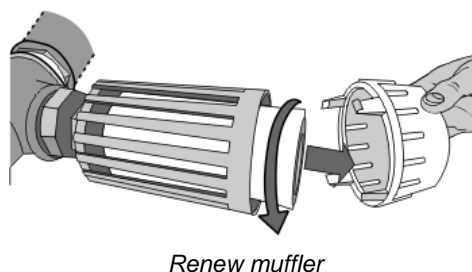

- ▶ Insert new filter element and screw on tightly.
- ▶ Re-engage lid cap at the top section of the housing and fix in position by means of the knurled screw.
- ▶ Restart dryer (see page 38).

Renew dewpoint sensor

To ensure precision dew point measurement, it is recommended to replace the dew point sensor every year. This period depends however on the actual application and might thus be extended accordingly.

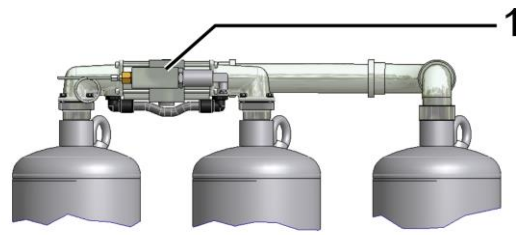

Dewpoint sensor (1)



Warning!

The dew point sensor is a sensitive measuring device. It can be damaged if subjected to forceful vibrations or shocks. Therefore, please handle the dew point sensor with great care at all times.

In order to limit the impact on the dryer operation to a minimum, we recommend that you contact the manufacturer well in advance (for contact details, see page 7) and order a new dewpoint sensor. After receipt of the new pressure dewpoint sensor, replace the sensor as follows:

- ▶ Hold the box of the dewpoint sensor ready.
- ▶ Release pressure from dryer and shut down the unit (see page 36)

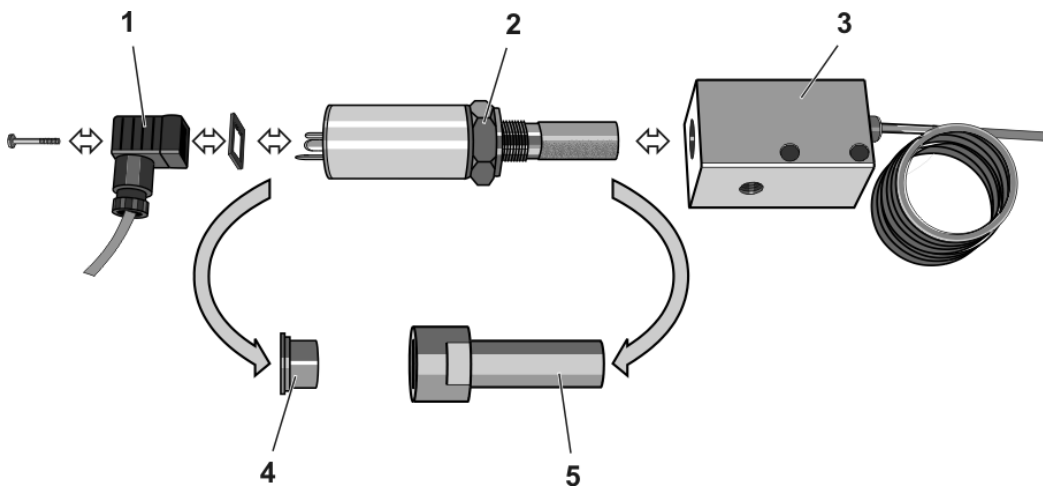

Installing / dismantling pressure dewpoint sensor

- ▶ Loosen the screw at the adapter (1) and disconnect signal cable with the adapter and seal.
- ▶ Remove dewpoint sensor from the sensor cell (3) by turning the nut (2).
- ▶ Take the new dewpoint sensor (2) from the box, remove the protective caps (4, 5) and screw it into the sensor chamber (3).
- ▶ Place seal onto sealing face; connect adapter (1) and secure it by tightening the screw.
- ▶ If no other maintenance work is to be carried out: Restart the dryer (see page 38).

Notes on further maintenance work

Every 12 months

Replacing pilot valves

The pilot valves are part of every service kit and must be replaced every 12 months.

Renew purifying agent

The active surface of the purifying agent can be reduced by oil residue and other contaminants. The purifying agent must therefore be replaced once every 12 months (after approx. 8,500 operating hours). If the compressed air is insufficiently dried before it reaches the adsorber (see technical data in the appendix), the service life of the purifying agent can be considerably shortened. In this case, the agent must be replaced every 6 months (after approx. 4,000 operating hours).

Every 24 months

Replacing inlet valves (V1/V2) and check valves (V5/V6)

The inlet valves (main valves) and the check valves are part of the 24-month service kits. Replace them every 2 years as a precautionary measure.

Expansion valves (V3/V4)

In addition to the inlet valves and the check valves, the expansion valves have to be replaced every 24 months as a precautionary measure.

Replacing solenoid coils

Solenoid coils come with the 24-month service kits. Replace them every 2 years.

Every 48 months

In accordance with national regulations, a pressure vessel inspection may be prescribed to be carried out at regular intervals by an independent supervisory office.

For an inspection of the pressure vessels, the drying and purifying agents must be removed.

When inspecting the pressure vessels, it is recommended to check the condition of all fittings such as e.g. sieve bottoms and dust sieves, including gaskets. If necessary, these fittings must be cleaned or renewed.

In the event of comprehensive maintenance or repair tasks, contact the manufacturer.

Renew drying agent

The service life of the drying agent is usually approx. 3 to 5 years. However, in favourable installation conditions, the change of drying agent may be carried out at a substantially later date (for notes on the installation site, see also page 14). The change interval depends very significantly from the degree of contamination in the compressed air (or the quality of the compressed air upstream filters). Oil, dust, and dirt particles cover the drying agent surface and reduce its effective surface, in part quite irreversibly.

Identify and eliminate faults

The following table provides information on what designatory abbreviations are to be used for the various components. These designations are also found in the technical documentation.

Abbreviation	Component
PI	Pressure gauge
PDI	Differential pressure gauge
V1–V2 (Y1–Y2)	Main valves (solenoid valves)
V3–V4 (Y3–Y4)	Expansion valves (solenoid valves)
V5–V6	Check valves

Summary of faults

There are different fault types. In the case of most electrically caused faults (e.g. short circuit, defective fuse, etc.) the expansion valve closes and the regeneration is interrupted. In the case of some process faults, the dryer will continue to operate for some time. Other faults on the dryer become noticeable e.g. due to unusual noises and ran pressures.

The following table shows who is allowed to remedy a fault: the owner's specialist personnel or the manufacturer's service engineer.

Table of possible faults

Fault	Possible cause	Remedy	Spec. personnel	Service engineer
Excessive dam pressure during regeneration	Muffler or filter element of the muffler is contaminated.	Check mufflers or filter elements for contamination, clean if nec., and poss. renew.	●	●
	Expansion valve V3/V4 does not open correctly.	Check expansion valve for contamination, if nec. clean/renew.	●	●
	Dust sieves are contaminated.	Clean or renew dust sieves.	●	●
Vessel pressure is too low	Excessive differential pressure on the upstream filter.	Check differential pressure on the upstream filter, if. nec. renew filter element.	●	
No pressure build up	The compressed air system upstream of the dryer is not pressurised.	Check whether the compressed air system upstream of the dryer is pressurised. Remove any faults.	●	
	Solenoid valve Y1/Y2 does not open correctly.	Check supply voltage, cable, contacts and solenoid; replace, if necessary.	●	●
Excessive compressed air consumption	Leakage.	Check condensate trap at the upstream filter; clean, if necessary.	●	●
Dryer does not switch over	Solenoid valve Y1/Y2 does not open correctly.	Check supply voltage, cable, contacts and solenoid; replace, if necessary.	●	●

Fault	Possible cause	Remedy	Spec. personnel	Service engineer
	Solenoid valve Y1/Y2 cannot be opened properly (audible humming sound or valve flapping).	Check supply voltage. Check pilot valves; replace, if necessary.	●	●
	Control board defective.	Check fuse in supply line and in the switchbox; replace, if necessary.	●	●
	Power supply interrupted, cable broken.	Reconnect the unit to the power supply.	●	
	Compressor might be off.	Check compressor synchronisation circuit.		
	Error in control programme.	Restart programme.		●
No expansion	Solenoid valve Y3/Y4 cannot be opened.	Check supply voltage, cable, contacts and solenoid; replace, if necessary.	●	●
	Solenoid valve Y3/Y4 cannot be opened properly (audible humming sound or valve flapping).	Check supply voltage. Check pilot valves; replace, if necessary. Check valve bodies for contamination; clean or replace, if necessary.	●	●
Dryer is continuously bled	Solenoid valve Y3/Y4 cannot be closed properly (audible humming sound or valve flapping).	Check supply voltage. Check solenoid and diaphragm; replace, if necessary.	●	●
	Main valve V1/V2 does not open.	Check main valve, replace if nec.	●	●
Dryer is excessively bled	Solenoid valve Y1/Y2 cannot be closed.	Check solenoid and diaphragm; replace, if necessary.	●	●
Pressure dew point is not reached	Operating pressure is too low.	Increase operating pressure.	●	
	Compressed air volume flow is too high.	Reduce compressed air volume flow	●	
	Compressed air inlet temperature is too high.	Reduce compressed air inlet temperature or pre-connect a compressed air cooler.	●	●
	Control board is defective.	Check control board, if nec. renew.		●
	Differential pressure on the upstream filter is too high.	Check differential pressure on the upstream filter, if nec. renew filter element.	●	
	Condensate trap on the upstream filter does not work.	Check function of the condensate trap, if nec. clean or renew.	●	●
	Drying agent is contaminated or too old.	Check upstream filter for contamination, if nec. renew element.	●	
		Check drying agent for contamination, if nec. renew drying agent.	●	●
	Regeneration gas too low.	Check function of expansion valve V3/V4 and muffler, if nec. renew muffler or filter element.	●	●
	sensor is defective	Replace sensor	●	●

With dewpoint-sensing control (optional)

Fault code	Description of fault	Possible cause	Remedy	Specialised personnel	Service technician
+20	Upper measuring range limit exceeded	Drying capacity exceeded.	See instructions for commissioning. If the drying agent is wet, replace it.	●	
999	Dewpoint sensor defective	Error in programme.	Restart programme.		●
sens or -999	Sensor not powered, or cable or sensor defective	Sensor defective or irreversibly contaminated.	Replace sensor.	●	●
SEr	Sensor, sensor cable or sensor adapter defective.	Visual inspection; check power supply (24 V to terminals 4 and 6). Replace defective component(s).	The display appears after every 8000 operating hours.	●	●
	Display for service interval. Regular maintenance tasks must be carried out.	Inform the manufacturer's service staff and order the appropriate service kit. The package includes a dongle with which you can reset the operating hours counter after maintenance has been carried out. For instructions on how to use the dongle see the enclosed information sheet (in the service kit).			

Index

A

Abbreviation	
Components	51
Address, manufacturer	7
Adsorption, explanation	18
Air ejection, sudden	12

B

Bolt connections	23
Build no.	39, 58
<i>Bypass line</i>	23

C

Changing cycle mode	
explanation	32
Check valves	
maintenance interval	40
Components	51
Compressed air	10, 18
Compressor synchronisation	
option	20
compressor synchronisation controller	20
Compressor synchronisation line	
installation	25
Connection lines	23
Connector	
electrical	24
Control	
dewpoint-sensing	20
Control system	
signalling contacts	20
Conversions	9
Cycle	
fixed	20
variable	20
Cycle mode change	
explanation	32

D

Danger notes	
Danger!	8
Danger warning, maintenance	39, 41
Date of manufacture	4
Dehumidification	
explanation	19
Dew point sensor	
maintenance interval	40
Dewpoint-sensing control	20

Digital display	
explanation	28
Documentation, technical	56
Dongle	
use	41
Dryer	
maintenance interval	40
drying agent	
handling	9
service life	50
Drying agent	
charging	20
maintenance interval	41
Drying agents	
storage	16
Dust generation	9, 38
Dust mask	9

E

Ear protection	34
Example for installation	23
Expansion, explanation	19
Eye protection	9

F

Fabrication no.	4
Fixed cycle	20
Flow diagram	62

H

Hazard areas	12
--------------	----

I

Installation area	14
Installation example	23
Installation site, requirements	14

L

LEDs	
explanation	27
lifting gear	13
Limits, permissible	34

M

Machine damage, prevention	9
Machine passport	4
main voltage	57
Maintenance	

dam pressure.....	42	maintenance interval.....	40
drying agent.....	50	Purifying agents	
Muffler.....	47	storage.....	16
purifying agent.....	49		
sensor.....	48	<hr/>	
Maintenance contract.....	39	R	
Maintenance, danger warnings.....	39, 41	Regeneration, explanation.....	18
Misuse.....	10	Regulations for accident prevention.....	13
Misuse, suspected.....	10	Replacement parts.....	39
Modifications on the dryer.....	9	Risk of skidding.....	12
Muffler			
maintenance interval.....	40	<hr/>	
		S	
<hr/>		Safety notes.....	9
N		general.....	9
Noise level.....	57	Warning!.....	8
Notes		Safety valves.....	22, 26
safe, efficient handling.....	8	Shutdown valves.....	23
		Shutting down.....	37
<hr/>		Signalling lines	
O		external.....	25
Oil indicator		Specialist personnel.....	8, 22
maintenance interval.....	40	Standard equipment.....	7
On/Off switch		Standby phase	
explanation.....	27	with dew point-sensing control.....	19
Operating instructions.....	7	Start-up device.....	20
safe place.....	8	Start-up, requirements.....	26
safety notes.....	9	Storage room	
target group.....	8	requirements.....	15
Operating overpressure		Supply cable, electrical.....	24
minimum, maximum.....	57	Supply lines.....	22
Operating pressure.....	31	Switchover	
permissible.....	4	explanation.....	20
safety device.....	22		
Operating signalling contact		<hr/>	
installation.....	25	T	
Operation signalling		Target group.....	8
contact.....	20	taype plate.....	11
Original replacement parts.....	39	Transport damage.....	13
Overpressure, hazard.....	12	transport lugs.....	15
<hr/>		<hr/>	
P		U	
Packaging.....	13	Use, intended.....	10
Personnel qualification.....	9, 41	Use, safe.....	8
Pressure build-up			
explanation.....	19	<hr/>	
sudden.....	31	V	
Pressure Conditions.....	37	Variable cycle.....	20
Pressure vessel.....	39	Vessel pressure gauge	
Programme		maintenance interval.....	40
sequence, steps.....	60	vibration dampers.....	15
Protection class.....	57	Visual inspection.....	42
purifying agent		Voltage	
handling.....	9	electrical.....	24
Purifying agent		Voltage, electrical.....	12

Annex with technical documentation

This annex comprises the following information and technical documentation:

- Technical data
- Replacement and wear parts list
- Measuring log of the oil indicator
- Logic control diagram
- Flow diagram
- Dimensional drawing

Technical data

Operating Range

Site Selection	frost-free indoor installation in a non-hazardous environment
Ambient temperature	1,5 to 50 °C (24,7 to 122 °F)
Compressed air inlet temperature	25 to 50 °C (68 to 122 °F)
max. operating overpressure	16 bar _e
operating overpressure, minimal	5 bar _e
Medium	Compressed air and gaseous nitrogen
Fluid group (acc. to the directive for pressure equipment)	2

Electrical connection

Main voltage, standard	230 V, 50-60 Hz
Alternative voltage	115 V, 50-60 Hz and 24 V DC
Protection class	IP65
Please heed to the type plate and enclosed wiring diagram!	

Performance data

Model	Volumetric flow in m ³ /h	Nominal pipe ²	Upstream filter	Downstream filter	Nominal Pressure in bar(e)	Nominal temperature in °C
KA-MT 10	105	1	GL9XLD	GL9ZLDH	16	50
KA-MT 15	145	1	GL9XLD	GL9ZLDH	16	50
KA-MT 20	200	1	GL9XLD	GL9ZLDH	16	50
KA-MT 25	255	1 1/2	GL11XLD	GL11ZLDH	16	50
KA-MT 35	350	1 1/2	GL11XLD	GL11ZLDH	16	50
KA-MT 45	420	1 1/2	GL12XLD	GL12ZLDH	16	50
KA-MT 60	620	2	GL13XLD	GL13ZLDH	16	50
KA-MT 75	750	2	GL13XLD	GL13ZLDH	16	50
KA-MT 95	940	2 1/2	GL14XLD	GL14ZLDH	16	50

¹ m³/h, relating to 1 bara and 20 °C at the compressor suction capacity. Subsequently compressed to 7 bar_e and 35°C inlet temperature to the dryer at 100 % relative humidity – for pressure dewpoints of -25 °C and -40 °C.

² In accordance with DIN ISO 228 (BSP-P)

Noise emission

Noise level: +3 dB (A) ¹	65 – 95 dB(A)
-------------------------------------	---------------

¹ relative to free field measurement, 1 m surr. field

drying agent

Vessel 1	100 % molecular sieve
Vessel 2	100 % molecular sieve
Vessel 3	100 % purifying agent activated carbon

Dimensions

Please heed to the dimensional drawings and the according table containing dimensions and weight on page 64.

Replacement and wear parts list

Note:

When exchange or replacement parts are ordered, always state the dryer type and the build no. of the dryer. These data are found on the type plate.

Service kits 12 and 36 months

For model	Mains voltage	Order-ID.	Scope of delivery
KA-MT 10 - KA-MT 20	115V, 230V	SKK10-K20/D2/12	Reset-modules, muffler, filter element, pilot-valves
KA-MT 25	115V, 230V	SKK25/D2/12	Reset-modules, muffler, filter element, pilot-valves
KA-MT 35	115V, 230V	SKK35/D2/12	Reset-modules, muffler, filter element, pilot-valves
KA-MT 45	115V, 230V	SKK45/D2/12	Reset-modules, muffler, filter element, pilot-valves
KA-MT 60 - KA-MT 75	115V, 230V	SKK60-K75/D2/12	Reset-modules, muffler, filter element, pilot-valves
KA-MT 95	115V, 230V	SKK95/D2/12	Reset-modules, muffler, filter element, pilot-valves

Service-Kits 24 und 48 Monate

For model	Mains voltage	Order-ID.	Scope of delivery
KA-MT 10 - KA-MT 20	115V	SKK10-K20/D2/24/115	Reset- modules, muffler, filter element, inlet- expansion- and check valves, solenoid
	230V	SKK10-K20/D2/24	
KA-MT 25	115V	SKK25/D2/24/115	Reset- modules, muffler, filter element, inlet- expansion- and check valves, solenoid
	230V	SKK25/D2/24	
KA-MT 35	115V	SKK35/D2/24/115	Reset- modules, muffler, filter element, inlet- expansion- and check valves, solenoid
	230V	SKK35/D2/24	
KA-MT 45	115V	SKK45/D2/24/115	Reset- modules, muffler, filter element, inlet- expansion- and check valves, solenoid
	230V	SKK45/D2/24	
KA-MT 60 - KA-MT 75	115V	SKK60-K75/D2/24/115	Reset- modules, muffler, filter element, inlet- expansion- and check valves, solenoid
	230V	SKK60-K75/D2/24	
KA-MT 95	115V	SKK95/D2/24/115	Reset- modules, muffler, filter element, inlet- expansion- and check valves, solenoid
	230V	SKK95/D2/24	

Additional spare parts

Order no.	Maintenance interval	Quantity	Scope of delivery
ZHM100/450	12 months	1	Dewpoint sensor
LS5/ZR	12 months	1	Element fine filter muffler
RK-MANO.063SR0219-1	When necessary	1	Vessel pressure gauge
P02/ZR	When necessary	1	Indicator tube for oil indicator OP0/21AKN

Desiccant packs

Type	Order -ID.	contents
KA-MT 10	K-MT10DESMIX	The desiccant packs contain enough drying agent to fill both vessels according to the 48 month maintenance interval.
KA-MT 15	K-MT15DESMIX	
KA-MT 20	K-MT20DESMIX	
KA-MT 25	K-MT25DESMIX	
KA-MT 35	K-MT35DESMIX	
KA-MT 45	K-MT60DESMIX	
KA-MT 60		
KA-MT 75	K-MT75DESMIX	
KA-MT 95	K-MT95DESMIX	

Activated carbon packages

Type	Order-ID.	Quantity	description
KA-MT 10	DESPAC10AK	1x	Activated carbon packs of different sizes. It may be necessary to combine several packs of different sizes to fill the vessel completely with activated carbon. In order to chose the correct amount of activated carbon packs, please heed to the table on the left.
KA-MT 15	DESPAC3AK	1x	
	DESPAC10AK	1x	
KA-MT 20	DESPAC3AK	2x	
	DESPAC10AK	1x	
KA-MT 25	DESPAC3AK	1x	
	DESPAC10AK	2x	
KA-MT 35	DESPAC10AK	3x	
KA-MT 45	DESPAC3AK	1x	
	DESPAC10AK	3x	
KA-MT 60	DESPAC10AK	5x	
KA-MT 75	DESPAC10AK	7x	
KA-MT 95	DESPAC10AK	9x	

Logic control diagram

Adsorption in B1 and regeneration in B2

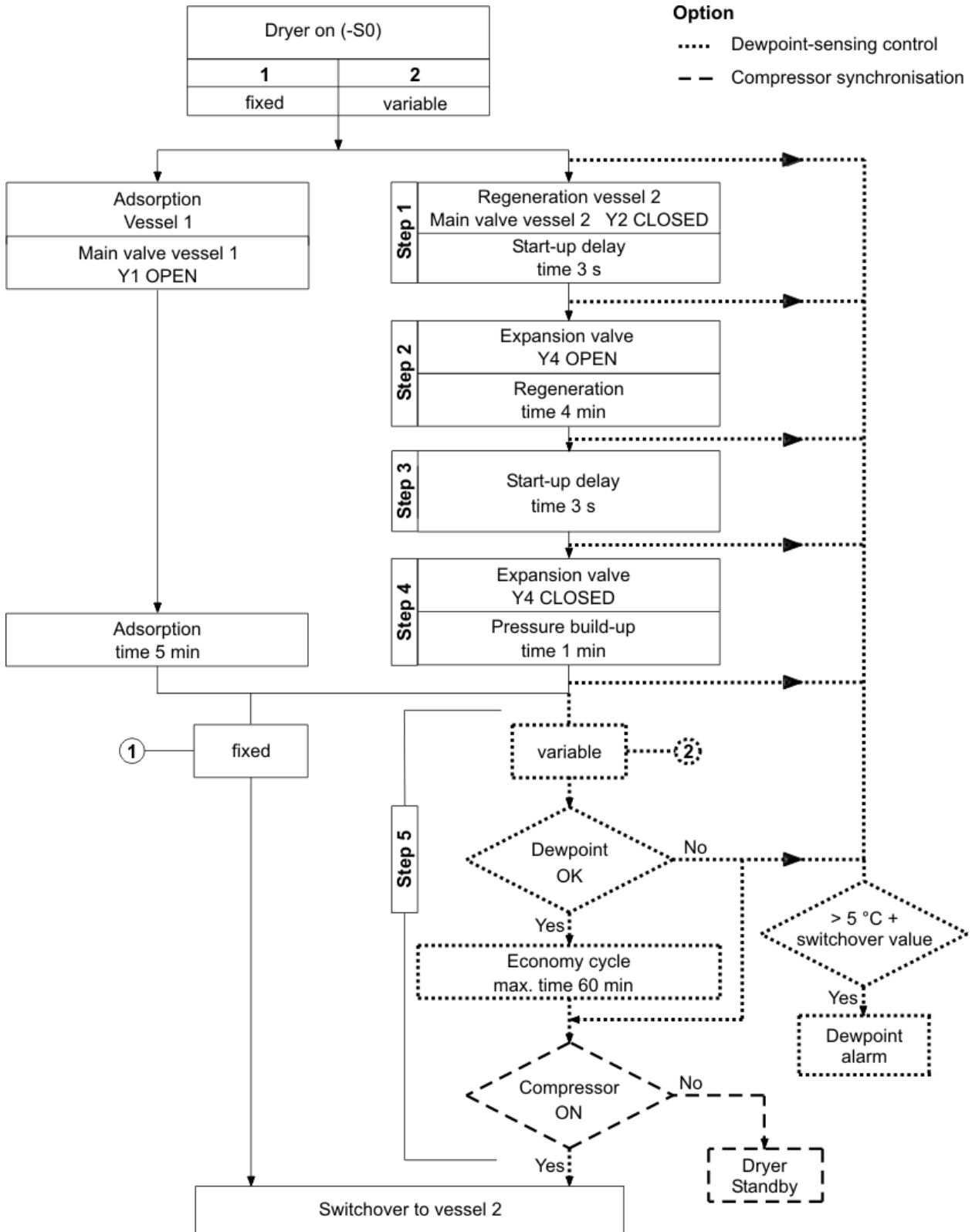

Regeneration in B1 and adsorption in B2

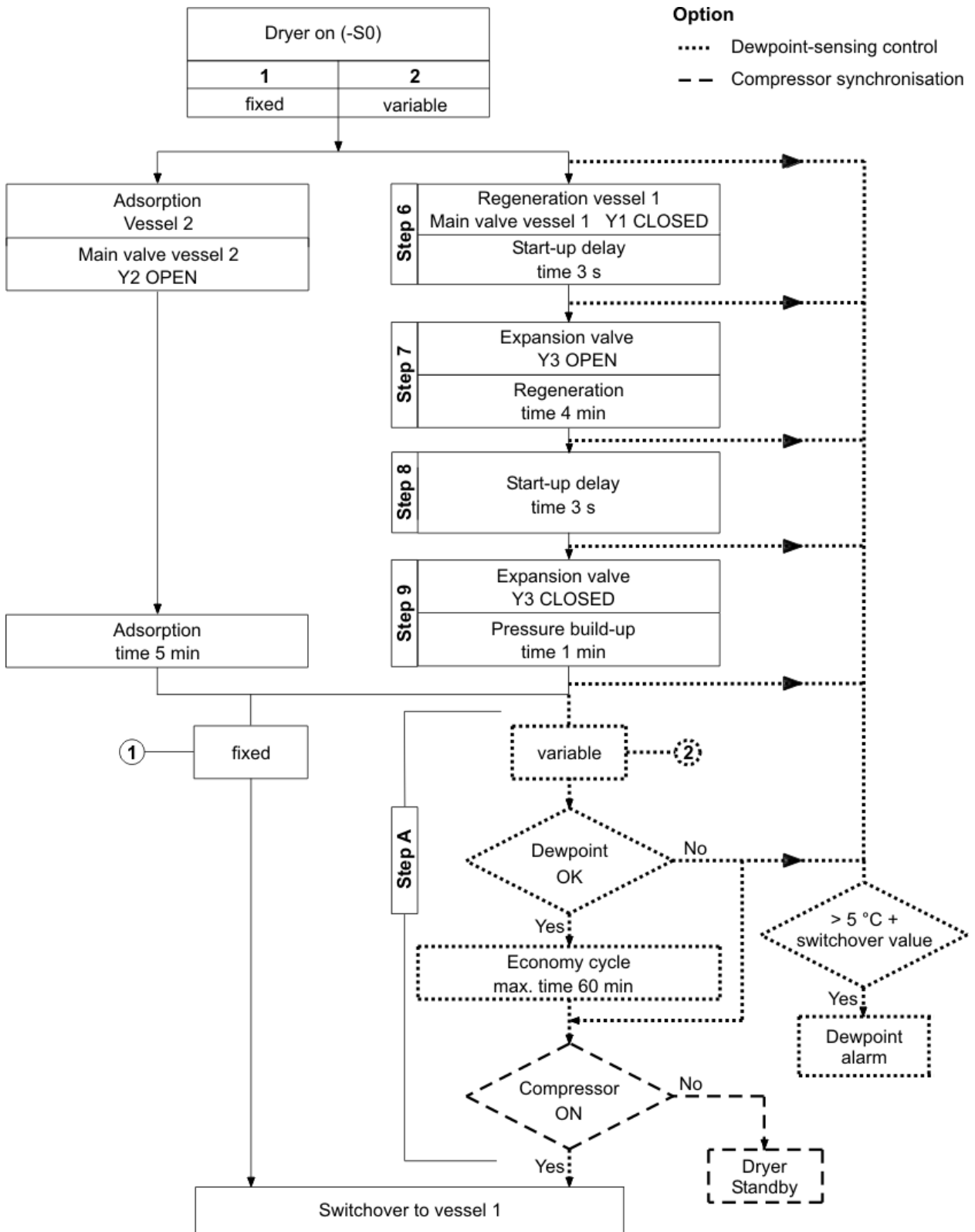

Flow diagram

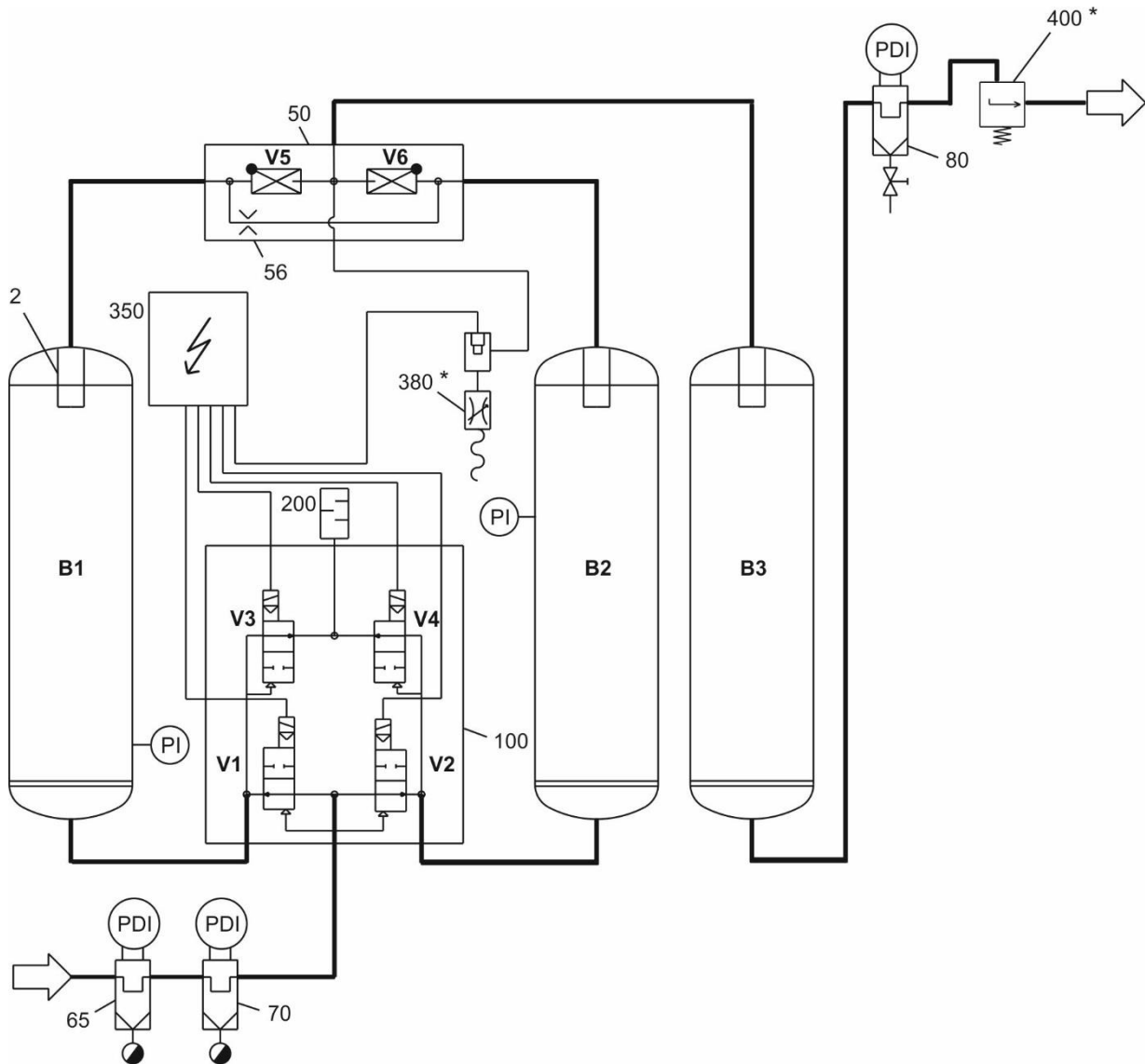

Pos.	Designation
1	Dust sieve
2	Check valve block V5–V6
3	Regeneration gas orifice plate
4	Upstream filter
5	Downstream filter
6	Solenoid valve block V1–V4
7	Oil indicator OP01

Pos.	Designation
8	Muffler
9	Control system
*	Optional devices:
10	Dewpoint-sensing unit
11	Start-up device

Dimensional drawing

KA-MT 10 & KA-MT 15

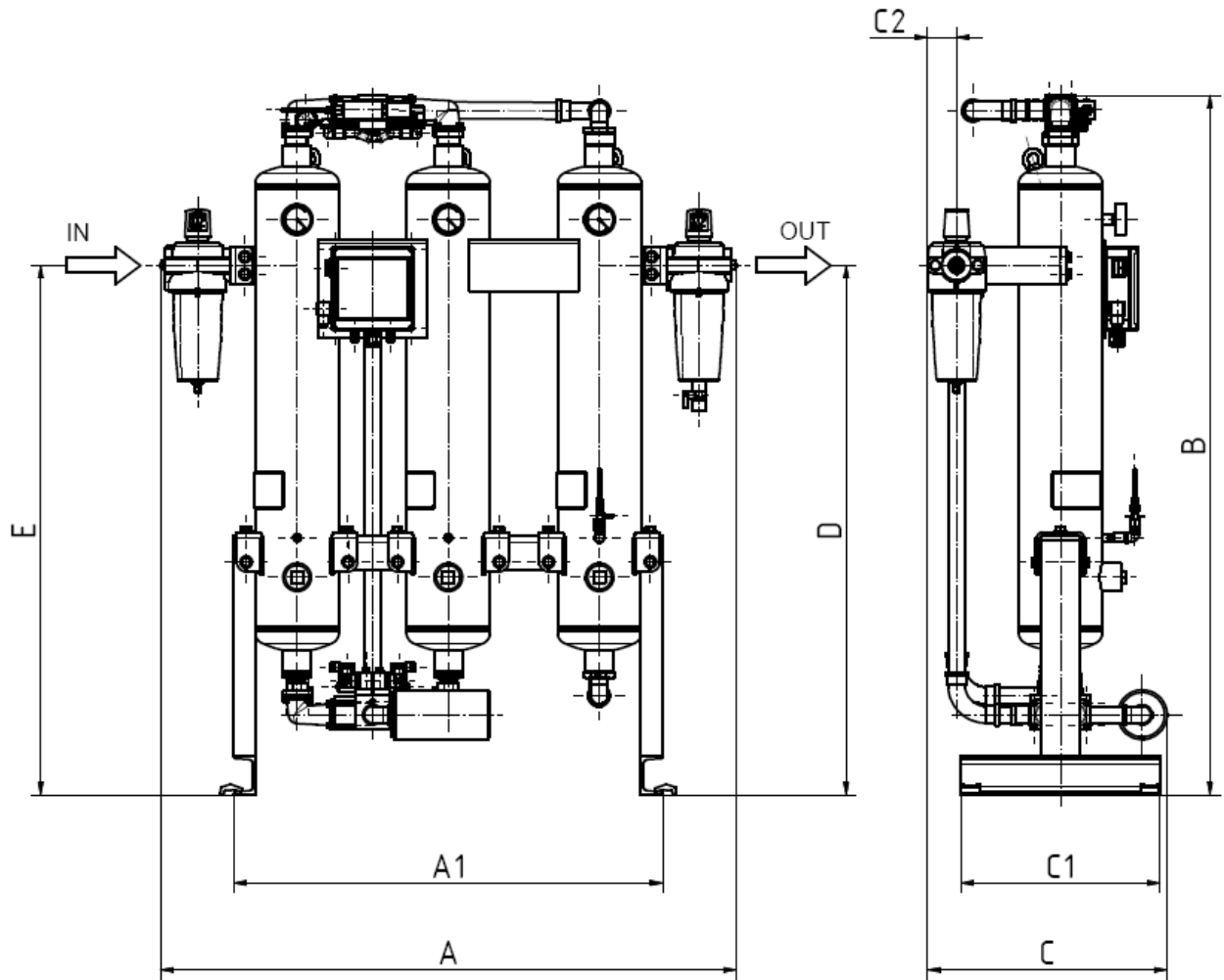

KA-MT 20 – KA-MT 95

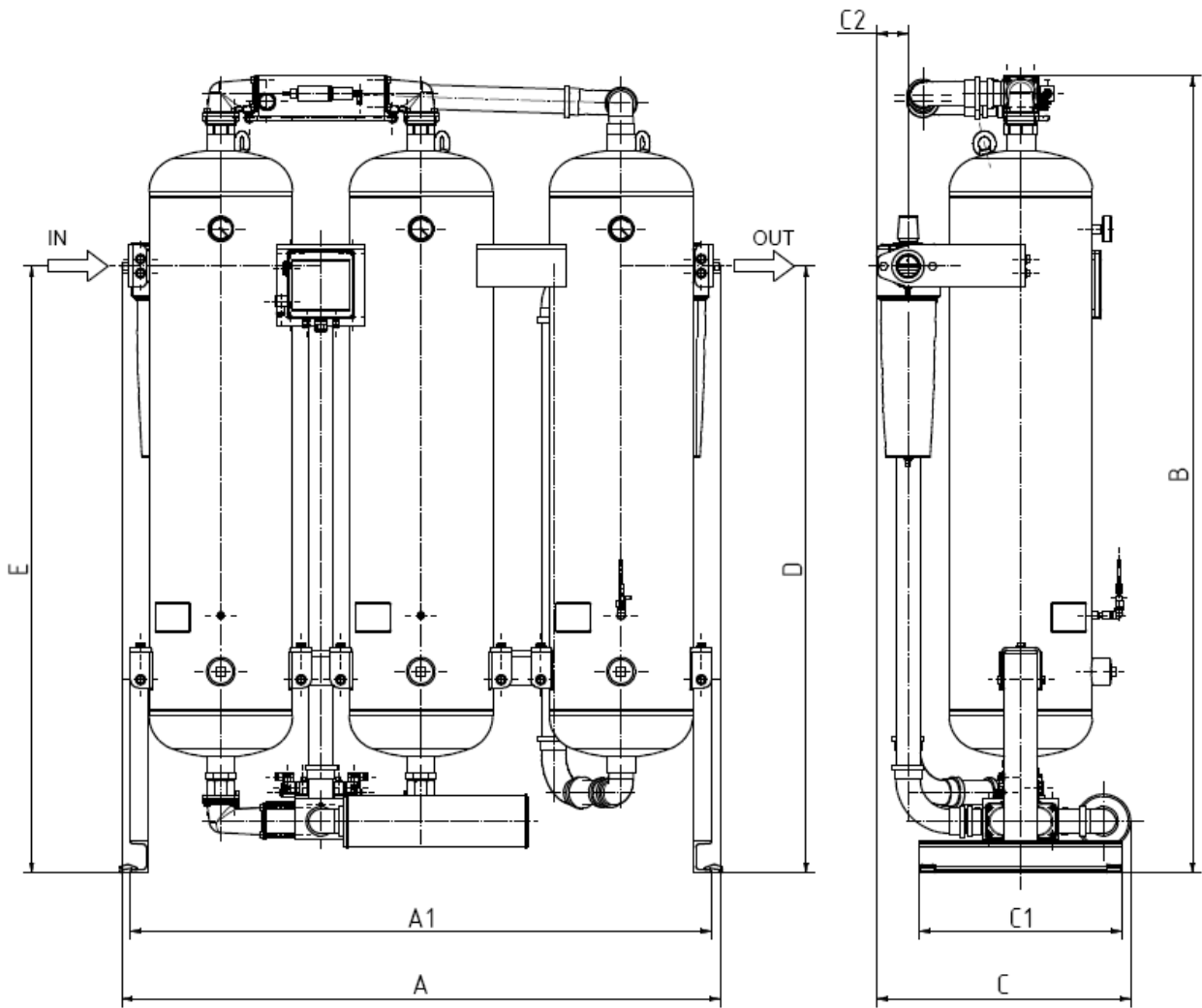

Type	Connection	Dimensions [mm]								Weight [kg]
		A	A1	B	C	C1	C2	D	E	
KA-MT 10	G 1	1170	880	1420	490	400	60	1070	1070	161
KA-MT 15	G 1	1170	880	1750	490	400	60	1320	1320	193
KA-MT 20	G 1	970	930	1530	490	400	60	1160	1160	193
KA-MT 25	G 1½	970	930	1760	530	400	60	1320	1320	234
KA-MT 35	G 1½	1260	1220	1810	585	400	60	1320	1320	283
KA-MT 45	G 1½	1290	1250	1820	605	400	80	1320	1320	334
KA-MT 60	G 2	1350	1290	1870	635	500	80	1320	1320	428
KA-MT 75	G 2	1500	1440	2000	640	500	80	1515	1515	555
KA-MT 95	G 2½	1550	1490	2020	670	500	80	1515	1515	698