

IOMI: 17 873 0002 06/22 Rev -

Preventative Maintenance Guide: 17 873 0054

# Breathing Air System

---

## Medium Flow

BAS HL 050 - BAS HL 085



Installation, Operation and  
Maintenance Instructions

(EN)



# CONTENTS

---

- 05 - Safety Information
- 06 - Markings and Symbols
  - Breathing Air Purifier Model Number Identification
- 08 - Receiving and Inspecting the Equipment
  - Storage
  - Unpacking
- 10 - Model Overview
- 14 - Overview of the Equipment
- 16 - Installation and Commissioning
  - Commissioning Check List
- 17 - Recommended System Layout
- 18 - Locating the Equipment
  - Mechanical Installation
- 21 - Electrical Installation
  - Breathing Air Purifier Electrical Supply
  - Commissioning - Controller Setup Basic Operation
- 22 - Check Inlet Valve Configuration (N/C or N/O)
  - Configure Temperature Units to be Displayed
- 23 - Commissioning - Controller Setup Advanced Installation
  - BAS HL Breathing Air Purifier Auxiliary Connections
- 24 - Purge Economy Connection
- 25 - Purge Economy Operation
- 26 - Remote Alarm Connection - General Fault Alarm

# CONTENTS

---

**27** - Remote Alarm Connection - Dedicated  
Dewpoint Alarm

**28** - 4-20mA Dewpoint Retransmission

**29** - Using the 4-20mA Signal

**30** - MODBUS Connectivity

**31** - MODBUS Strings

**33** - Changing MODBUS Communication  
Settings via ADS Service Software

**35** - Overview of Operation

**36** - BAS HL Operation

**40** - Operating the Breathing Air Purifier  
- Displays and Indicators

**48** - Service Intervals

**49** - Preventative Maintenance Kits

**52** - Technical Specification

**54** - Approvals Compliance and Exemptions

**55** - Weights and Dimensions

**56** - Trouble shooting

# SAFETY

# SAFETY INFORMATION

Do not operate this equipment until the safety information and instructions in this user guide have been read and understood by all personnel concerned.

## USER RESPONSIBILITY

FAILURE OR IMPROPER SELECTION OR IMPROPER USE OF THE PRODUCTS DESCRIBED HEREIN OR RELATED ITEMS CAN CAUSE DEATH, PERSONAL INJURY AND PROPERTY DAMAGE.

This document and other information from Parker-Hannifin Corporation, its subsidiaries and authorised distributors provide product or system options for further investigation by users having technical expertise.

The user, through its own analysis and testing, is solely responsible for making the final selection of the system and components and assuring that all performance, endurance, maintenance, safety and warning requirements of the application are met. The user must analyse all aspects of the application, follow applicable industry standards, and follow the information concerning the product in the current product catalogue and in any other materials provided from Parker or its subsidiaries or authorised distributors.

To the extent that Parker or its subsidiaries or authorised distributors provide component or system options based upon data or specifications provided by the user, the user is responsible for determining that such data and specifications are suitable and sufficient for all applications and reasonably foreseeable uses of the components or systems.

The pressure envelope of the equipment must not be breached under any circumstances. Failure to comply may result in an unplanned release of pressure, and may cause serious personal injury or death. All maintenance procedures that require the pressure envelope to be breached must only be performed by competent personnel trained, qualified, and approved by Parker.

Use of the equipment in a manner not specified within this Installation, Operation and Maintenance Instructions (IOMI) may result in an unplanned release of pressure, which may cause serious personal injury or damage.

When handling, installing or operating this equipment, personnel must employ safe engineering practices and observe all related regulations, health & safety procedures, and legal requirements for safety.

Ensure that the equipment is depressurised and electrically isolated, prior to carrying out any of the scheduled maintenance instructions specified within this user guide.

Only competent personnel trained, qualified, and approved by Parker should perform installation, commissioning, service and repair procedures.

Parker can not anticipate every possible circumstance which may represent a potential hazard. The warnings in this manual cover the most known potential hazards, but by definition can not be all-inclusive. If the user employs an operating procedure, item of equipment or a method of working which is not specifically recommended by Parker the user must ensure that the equipment will not be damaged or become hazardous to persons or property.

Most accidents that occur during the operation and maintenance of machinery are the result of failure to observe basic safety rules and procedures. Accidents can be avoided by recognising that any machinery is potentially hazardous.

### **Safety of the user is of paramount importance.**

The BAS HL Breathing Air Purifier has been designed to deliver breathable quality compressed air from a standard compressed supply (which contains up to 15 harmful contaminants).

The BAS HL control system includes an integrated dewpoint hygrometer to indicate outlet pressure dewpoint after the adsorption dryer stage (the stage responsible for water vapour and CO<sub>2</sub> reduction) as this is a good indicator of the correct functioning of the equipment.

The BAS HL control system **DOES NOT** include any monitoring of Carbon Monoxide (CO) or Carbon Dioxide (CO<sub>2</sub>) in the outlet air stream.

Parker recommend the installation of additional safety monitoring equipment for real time detection of Carbon Monoxide (CO) and Carbon Dioxide (CO<sub>2</sub>).

The additional safety monitoring equipment should include alarm features that warn the user if the Carbon Monoxide (CO) or Carbon Dioxide (CO<sub>2</sub>) levels exceed the local legally permitted values.

Always ensure the equipment is in BAS mode before use - check colour display screen for BAS mode icon















Details of your nearest Parker sales office can be found at [www.parker.com/gsfe](http://www.parker.com/gsfe)

Retain this Installation, Operating and Maintenance Instructions (IOMI) for future reference.

# MARKINGS AND SYMBOLS

The following markings and international symbols are used on the equipment or within this user guide:

	Caution, Read the User Guide.		Wear ear protection.
	Risk of electric shock.		Pressurised components on the system.
 <b>Warning</b>	Highlights actions or procedures which, if not performed correctly, may lead to personal injury or death.		Safety gloves to be worn
 <b>Caution</b>	Highlights actions or procedures which, if not performed correctly, may lead to damage to this product.		Conformité Européenne
 <b>Warning</b>	Highlights actions or procedures which, if not performed correctly, could lead to electric shock.		Dispose in accordance with local regulations
	Read the User Guide.		
	Use a forklift truck to move the equipment		

## BREATHING AIR PURIFIER MODEL NUMBER IDENTIFICATION

			050					
			055					
			060					
			065					
			070					
			075					
			080		N (NPT)			
BAS	HL (Heatless)	085	-40	G (BSPP)	16	A (AC 85-265V 50/60Hz)	Electronic	
SERIES	REGEN TYPE	MODEL	DEWPOINT	CONNECTIONS	MAX PRESSURE	POWER SUPPLY	CONTROLLER	
<b>Example</b>	BAS	HL	050	-40	G	16	A	E

# RECEIVING AND INSPECTING THE EQUIPMENT

# RECEIVING AND INSPECTING THE EQUIPMENT

The Breathing Air Purifier is supplied in a sturdy wooden crate designed to be moved using a forklift truck or pallet truck. Refer to the technical specification for packed weights and dimensions. On delivery of the equipment check the crate and its contents for damage. If there are any signs of damage to the crate, or there are any parts missing please inform the delivery company immediately and contact your equipment supplier or local Parker sales company.

## Transportation

The equipment must be kept upright at all times, including during transportation, storage and unpacking.

## Storage

The equipment should be stored, within the packing crate, in a clean dry environment. If the crate is stored in an area where the environmental conditions fall outside of those specified in the technical specification, it should be moved to its final location (installation site) and left to stabilise prior to unpacking. Failure to do this could cause condensing humidity and potential failure of the equipment.

## Unpacking

Remove the lid (A) and then all four sides of the packing crate (B). Carefully move the Breathing Air Purifier to its final location, using a forklift truck or pallet truck.

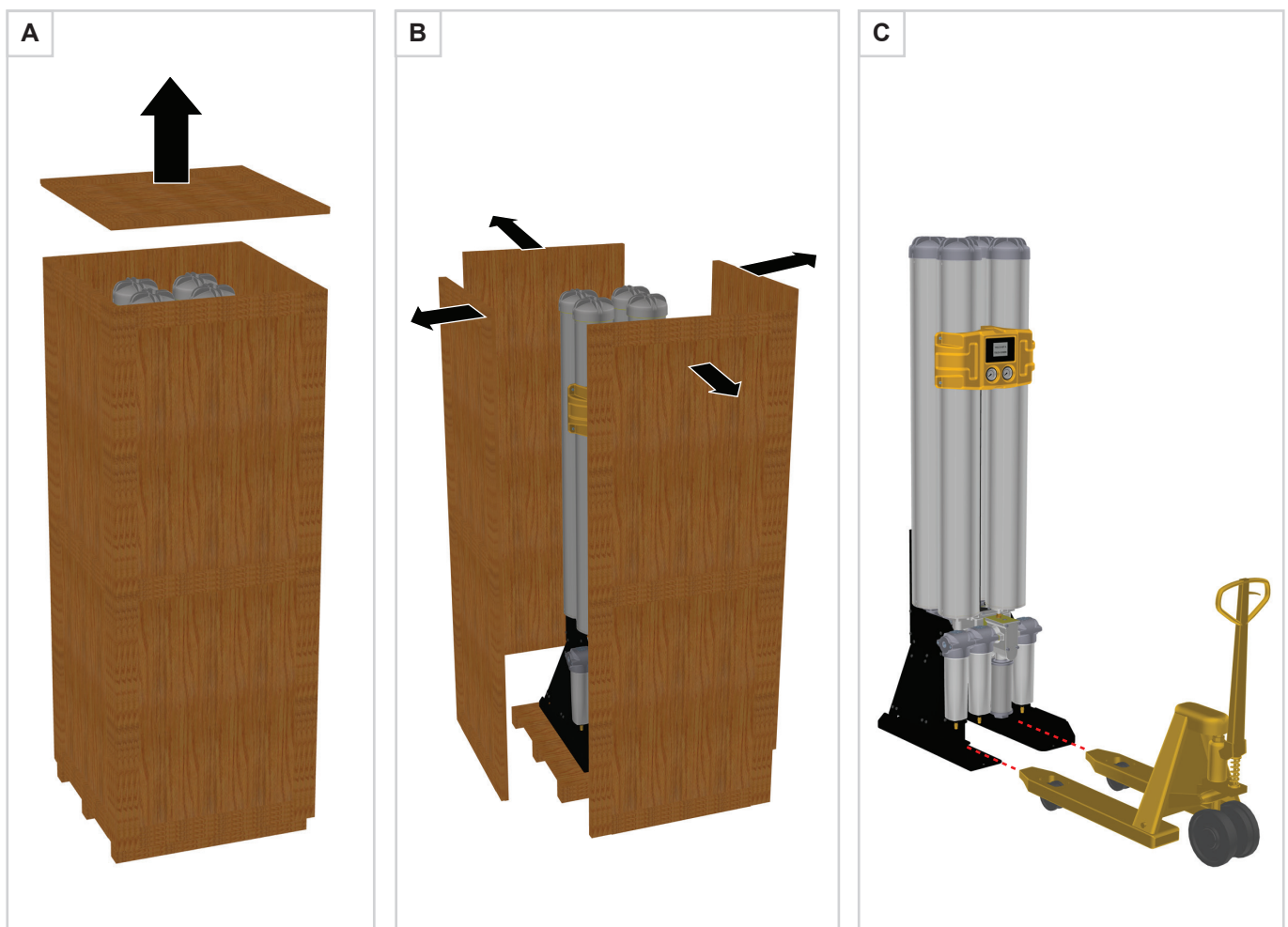

# MODEL OVERVIEW

# Model Overview

BAS HL is a complete purification systems designed to reduce the major contaminants found in a compressed air system and deliver breathable quality compressed air that meets and exceeds ISO 8573-1:2010 (the international standard for compressed air purity) Class 1:2:0, EN 12021:2014, European Pharmacopoeia (Ph. Eur.) 10th Edition, OSHA Grade D (ANSI/CGA Commodity Specification for Air - Seventh Edition, G-7.1-1989), CSA Z180.1:19 and AS/NZS 1715:2009.

RANGE		Number of Contaminants Treated (With Optional Water Separator)	Number of Purification Stages (With Optional Water Separator)	ISO 8573-1:2010 Classifications
BAS	Breathing Air System	7 (9)	4 (5)	1:2:0 (<0.003mg/m <sup>3</sup> total oil) / 1:2:1 (PDP ≤-40°C)

## MODEL: BAS HL - BREATHING AIR SYSTEM

**1**

**General Purpose Coalescing Filter**  
REDUCES:  
Particulate down to 1 micron  
Water & Oil Aerosols down to 0.5 mg/m<sup>3</sup>

**2**

**High Efficiency Coalescing Filter**  
REDUCES:  
Particulate down to 0.01 micron  
Water & Oil Aerosols down to 0.01 mg/m<sup>3</sup>

**3**

**Adsorption Dryer**  
REDUCES:  
Water Vapour - PDP ≤-40°C  
Carbon Dioxide (CO<sub>2</sub>) ≤ 500 ppm  
  
Low PDP also Inhibits Growth of Micro-organisms

**4**

**Activated Carbon Filter**  
REDUCES:  
Oil vapours down to <0.003 mg/m<sup>3</sup>  
Nitrogen Oxides (NO + NO<sub>2</sub>) ≤ 2 ppm  
Sulphur Dioxide (SO<sub>2</sub>) ≤ 1 ppm

**5**

**Catalyst Stage**  
REDUCES:  
Carbon Monoxide (CO) by conversion into Carbon Dioxide (CO<sub>2</sub>)

**6**

**General Purpose Dry Particulate Filter**  
REDUCES:  
Particulate down to 1 micron

**7**

**High Efficiency Dry Particulate Filter**  
REDUCES:  
Particulate & Micro-organisms down to 0.01 micron with an efficiency of 99.9999%

**\* Important Note**  
Should there be liquid water or liquid oil present at the inlet of the BAS HL Purifier, an additional OIL-X WS Grade Water Separator can be installed, increasing the number of contaminants treated to 15.

# PARKER BAS HL TESTED & VERIFIED

Parker BAS HL has been tested in accordance with the following international standards relating to compressed air purity.

PARKER BAS TREATMENT STAGE	PARKER TREATMENT TECHNOLOGY	CONTAMINANT	PERFORMANCE	TESTED IN ACCORDANCE WITH
Optional	Parker OIL-X Grade WS Liquid Separator	Liquid Water	>92% Liquid Removal	ISO 12500-4 ISO 8573-9
Optional		Liquid Oil		
Stage 1	Parker OIL-X Grade AO Coalescing Filter	Atmospheric Particles	Down to 1 micron @ 99.925% Efficiency	ISO 8573-4
		Rust		
		Pipescale		
		Water Aerosols	< 0.5mg/m <sup>3</sup> @ 99.925% Efficiency	ISO 12500-1 ISO 8573-2
Oil Aerosols				
Stage 2	Parker OIL-X Grade AA Coalescing Filter	Atmospheric Particles	Down to 0.01 micron @ 99.9999% Efficiency	ISO 8573-4
		Rust		
		Pipescale		
		Micro-organisms		
		Water Aerosols	< 0.01mg/m <sup>3</sup> @ 99.9999% Efficiency	ISO 12500-1 ISO 8573-2
Oil Aerosols				
Stage 3	Parker BAS Dryer	Water Vapour	≤ -40°C PDP	ISO 7183 ISO 8573-3
		Carbon Dioxide (CO <sub>2</sub> )	≤ 500 ppm	ISO 8573-6 European Pharmacopoeia
Stage 4	Parker OVR	Oil Vapour	≤ 0.003 mg/m <sup>3</sup>	ISO 8573-5
		Nitrogen Oxides (NO / NO <sub>2</sub> )	≤ 2 ppm v/v	ISO 8573-6 European Pharmacopoeia
		Sulphur Dioxide (SO <sub>2</sub> )	≤ 1 ppm v/v	ISO 8573-6 European Pharmacopoeia
Stage 5	Parker Catalyst	Carbon Monoxide (CO)	≤ 5 ppm	ISO 8573-6 European Pharmacopoeia
Stage 6	Parker OIL-X Grade AO Dry Particulate Filter	Dry Particulate	Down to 1 micron @ 99.925% Efficiency	ISO 8573-4
Stage 7	Parker OIL-X Grade AA Dry Particulate Filter	Dry Particulate	< 0.01mg/m <sup>3</sup> @ 99.9999% Efficiency	ISO 8573-4
		Micro-organisms		

# PARKER BAS HL DELIVERED AIR QUALITY

Parker BAS HL Breathing Air System has been designed to provide breathable quality compressed air that meets or exceeds the levels shown in the following global breathing air standards.

Contaminant Oxygen % Odours	EN12021:2014	European Pharmacopoeia	Osha Grade D	CSA Z180.1	Parker BAS	Parker BAS Treatment Stage
Atmospheric Particles	Not Specified	Not Specified	Not Specified	Not Specified	Particle & Micro-organism reduction down to 0.01 micron @ 99.9999% efficiency	Stage 1 & 2
Rust	Not Specified	Not Specified	Not Specified	Not Specified		
Pipescale	Not Specified	Not Specified	Not Specified	Not Specified		
Micro-organisms	Not Specified	Not Specified	Not Specified	Not Specified		Stage 6 & 7
Liquid Water	No Free Water	Not Specified	Not Specified	Not Specified	No Free Water	Optional WS
Water Aerosols			Not Specified	Not Specified	≤ 0.01 mg/m <sup>3</sup>	Stage 1 & 2
Water Vapour	≤ -11°C PDP	≤ 67ppm (≤ -45°C ADP)	Not Specified	< -53°C ADP	≤ -40°C PDP (≤ -57°C ADP)	Stage 3
Liquid Oil	Total Oil ≤ 0.5 mg/m <sup>3</sup>	Total Oil ≤ 0.1 mg/m <sup>3</sup>	< 5 mg/m <sup>3</sup>	< 1 mg/m <sup>3</sup>	Total Oil ≤ 0.003 mg/m <sup>3</sup>	Optional WS
Oil Aerosols						Stage 1 & 2
Oil Vapour						Stage 4
Carbon Monoxide (CO)	≤ 5 ppm	≤ 5 ppm v/v	< 10 ppm	< 5 ppm	≤ 5 ppm	Stage 5
Carbon Dioxide (CO <sub>2</sub> )	≤ 500 ppm	≤ 500 ppm v/v	< 1000 ppm	< 500 ppm	≤ 500 ppm	Stage 3
Nitrogen Oxides (NO / NO <sub>2</sub> )	Not Specified	≤ 2 ppm v/v	Not Specified	Not Specified	≤ 2 ppm	Stage 4
Sulphur Dioxide (SO <sub>2</sub> )	Not Specified	≤ 1 ppm v/v	Not Specified	Not Specified	≤ 1 ppm	Stage 4
Oxygen	(21 ± 1) %	20.4% ~ 21.4% v/v	19.5% - 23.5%	20% - 22%	As Inlet Concentration	As Inlet concentration
Odours	The gas shall be free from unsatisfactory odour or taste	Not Specified	Lack of noticeable odour	No pronounced odour	No Odours	Stages 3 & 4

# OVERVIEW OF THE EQUIPMENT

## BAS HL - BREATHING AIR PURIFIER

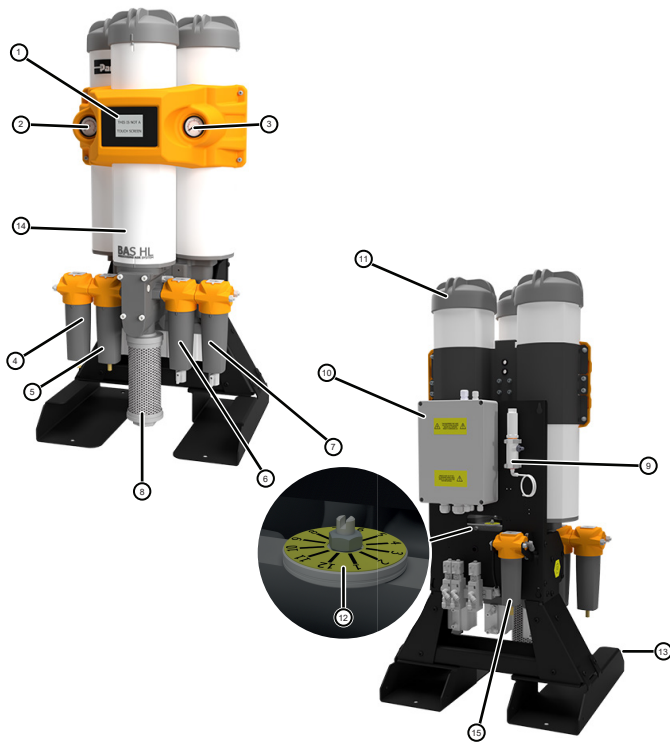

**Representation of Models BAS HL050 to BAS HL070**

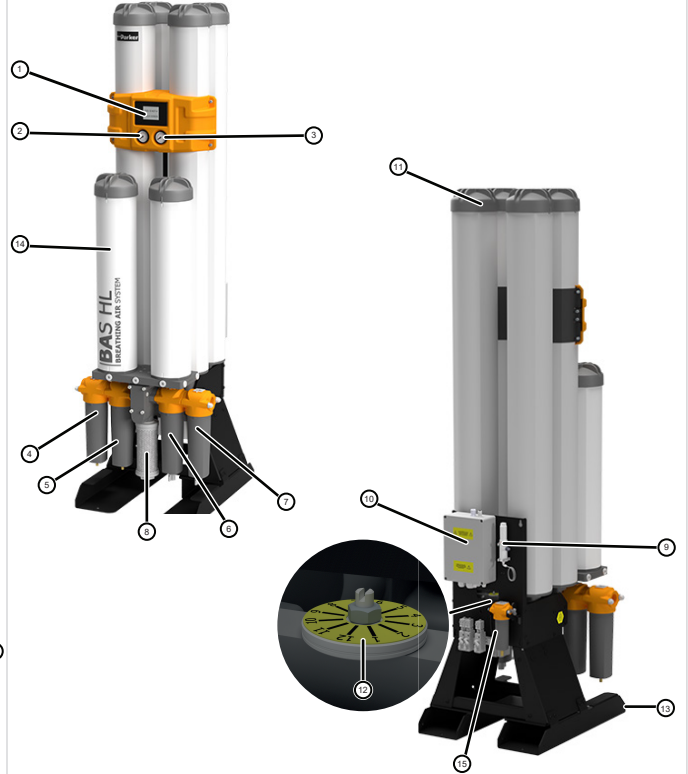

**Representation of Models BAS HL075 to BAS HL085**

REF	DESCRIPTION	REF	DESCRIPTION
1	Display	9	Dewpoint sensor
2	Column 1 pressure gauge	10	Control box
3	Column 2 pressure gauge	11	Column caps
4	General purpose coalescing filter (Grade AO)	12	Adjustable purge disc
5	High efficiency coalescing filter (Grade AA)	13	Pallet truck lifting points
6	General purpose dry particulate filter (Grade AO)	14	Oil vapour reduction stage
7	High efficiency dry particulate filter (Grade AA)	15	Control valve filter (Grade AA)
8	Exhaust silencer		

# INSTALLATION AND COMMISSIONING

# INSTALLATION AND COMMISSIONING



Only competent personnel trained, qualified, and approved by Parker Hannifin should perform installation, commissioning, service and repair procedures.

**Warning**

## COMMISSIONING CHECK LIST

TASK	PAGE	COMMENTS	TICK WHEN OK
<b>Recommended System Layout</b>			
System Components / piping installation	19		
<b>Locating the Equipment</b>			
Installation Environment	20		
Ensure adequate space for installation / maintenance	20		
Mechanical Installation	20		
Set purge for minimum inlet pressure	21		
<b>Electrical Installation</b>			
Breathing Air Purifier electrical connection	22		
<b>Commissioning - Controller Basic Installation</b>			
Configure Dewpoint Setpoint / Dewpoint Alarm Setpoint	22		
Configure Temperature Units to be Displayed - °C or °F	23		
<b>Commissioning - Controller Setup Advanced Installation</b>			
Remote Stop / Start Connection	25		
Purge Economy Connection	26		
Remote Alarm Connection - General Fault Alarm Relay	28		
Remote Alarm Connection - Addition of a Dedicated Dewpoint Alarm Relay	29		
4-20mA Dewpoint Retransmission	30		
MODBUS Connectivity	32		
MODBUS Strings	33		
MODBUS Setup via ADS Software	34		
<b>Final Check</b>			
Check equipment is set up in BAS mode	43		
Pressurisation / Leak check	N/A		
<b>Operation</b>			
Breathing Air Purifier start-up procedure	45		
Monitor operation / performance			
Troubleshooting (if required)	64		
<b>Installation and Commissioning Complete</b>			

# RECOMMENDED SYSTEM LAYOUT

BAS HL Breathing Air Purifiers can be installed directly after an air compressor or downstream of a wet air receiver. The preferred method of installation is downstream of a wet air receiver as the air receiver acts as a pre-cooler / liquid separator and is effective at protecting the Breathing Air Purifier from bulk liquid contamination and small temperature spikes.

### Water Separator (Optional)

Should BAS HL be installed directly after the air compressor (no wet air receiver) or the distance from the outlet of the wet air receiver is >3m, an optional OIL-X Grade WS water separator should be installed. Water separators are used to protect the coalescing filters included with BAS HL from liquid contamination. If liquid water / oil is not treated prior to the Breathing Air Purifier, dewpoint performance may not be achieved, and any remaining warranty will be invalidated.

### General Purpose and High Efficiency Coalescing Filters (included)

Coalescing filters are probably the single most important items of purification equipment in a compressed air system. They are designed to not only reduce aerosols (droplets) of oil and water using mechanical filtration techniques, but also to reduce solid particulate to very low levels (as small as 0.01micron in size). Installed in pairs, the first filter is a 'General Purpose Filter' which protects the second 'High Efficiency Filter' from bulk contamination. The included dual filter installation ensures a continuous supply of high quality compressed air with the additional benefits of low operational costs and minimal maintenance.

### Dry Particulate Filters (included)

BAS HL Breathing Air Purifiers includes a pair of Dry Particulate Filters for the reduction of desiccant particulates and micro-organisms. They provide identical particulate reduction performance to the equivalent coalescing filter and use the same mechanical filtration techniques to provide particle reduction.

### Important Note

Failure maintain the pre and post filtration supplied with the Breathing Air Purifier will lead to serious health consequences for the user and will invalidate the Breathing Air Purifier's warranty.

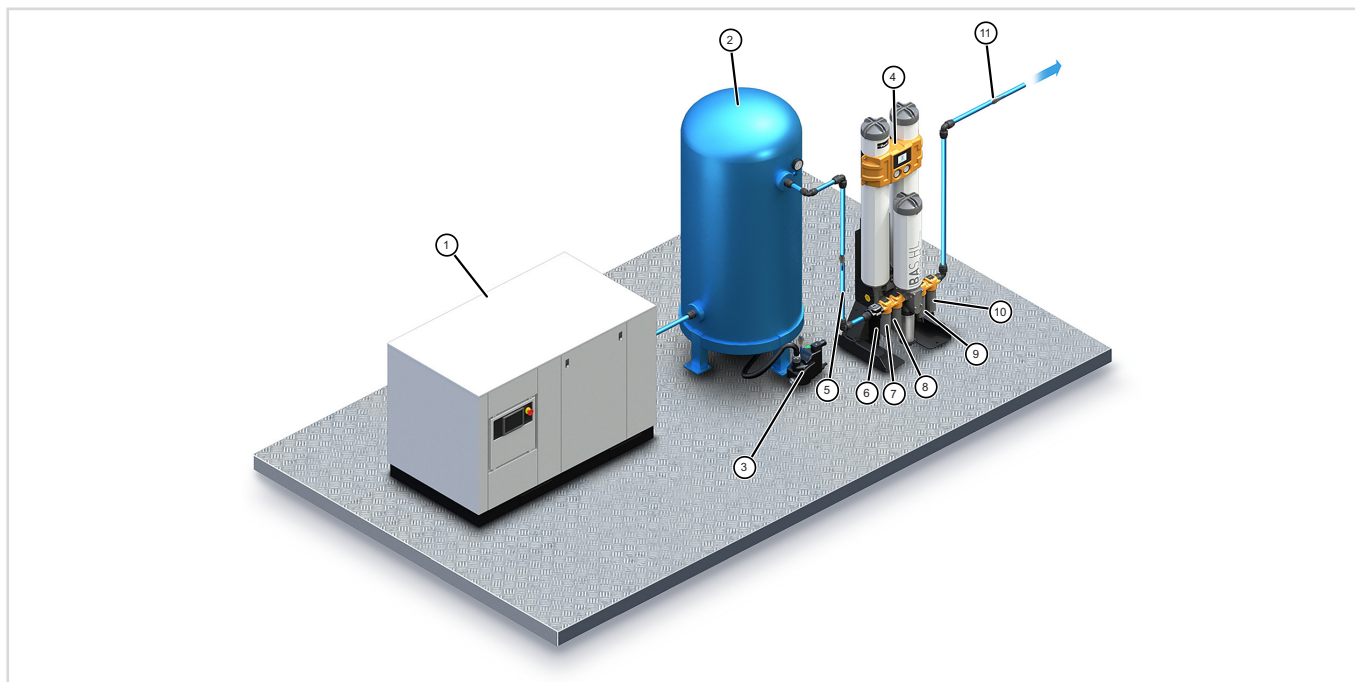

REF	DESCRIPTION	REF	DESCRIPTION
1	Compressor	7	General Purpose Coalescing Filter
2	Wet Air Receiver	8	High Efficiency Coalescing Filter
3	Electronic Condensate Drain (Not Included)	9	General Purpose Dry Particulate Filter
4	Medium Flow Breathing Air Purifier	10	High Efficiency Dry Particulate Filter
5	Isolation Valve (Not Included)	11	Non-Return Valve (not included)
6	Water Separator (Optional)		

### Important Notes: Protecting The Breathing Air Purifier from Reverse Flow

- Compressed air Breathing Air Purifiers are designed to flow in one direction only.
- Back flow (reverse flow) must not be allowed or damage to the filtration and Breathing Air Purifier may occur.
- BAS HL includes an integrated Non-Return Valve as standard to prevent damage to the Breathing Air Purifier.

# LOCATING THE EQUIPMENT

## Environment

The equipment should be located indoors in an environment that protects it from direct sunlight, moisture, and dust. Changes in temperature, humidity, and airborne pollution will affect the environment in which the equipment is operating and may impair the safety and operation. It is the customers' responsibility to ensure that the environmental conditions specified for the equipment are maintained.

## Space Requirements

The equipment should be mounted on a flat surface capable of supporting its own weight plus the weight of all ancillary parts. There must be adequate space around the equipment to allow airflow and access for maintenance purposes and lifting equipment. A minimum spacing of approximately 500mm (20 ins) is recommended around all sides of the Breathing Air Purifier and 750mm (29.5 ins) above it for the removal of the desiccant cartridges.

Do Not position the equipment so that it is difficult to operate or disconnect from the electrical supply.

# MECHANICAL INSTALLATION

## General Requirements

Ensure that each condensate drain is suitably piped away and any effluent is disposed of in a legal and responsible manner and in accordance with local environmental regulations. Condensate drain lines should never be connected together - connect to a common, vented condensate manifold. Condensate drain lines should be of large internal diameter and short length to eliminate back pressure which would prevent drainage of condensate. Condensate discharged from water separator and filter float drains will lose pressure once it enters the piping. Installing drain lines at height will result in a failure to remove condensate and loss of Breathing Air Purifier dewpoint.

### Important Notes:

- Breathing Air Purifier performance may be degraded and warranty will be invalid if above requirements are not followed.
- It is important to ensure that all inlet and outlet piping materials are suitable for the application, clean and debris free.
- The internal diameter of the inlet and outlet piping must be sufficient to allow an unrestricted air flow into and out of the equipment .
- When routing, the piping, ensure that they are adequately supported to prevent damage and leaks in the system.



**Warning**

**The system must be protected with a suitably rated thermal pressure relief valve.**

# SIDE MOUNTING THE REAR PANEL

For installations where space is limited (for example if the Breathing Air Purifier is placed against a wall), it may be beneficial to install the rear panel assembly to the side of the Breathing Air Purifier to provide easier access to the electrical control box, dewpoint sensor & control valves.

### Important Notes:

- Piping between the 5/2 valves and cylinders requires exchanging with longer piping (not supplied). The length of piping required is tabled below.
- The values quoted are for the longest hose needed and for certain models may be trimmed shorter for neatness.
- **PTFE hygrometer piping, must be a single length of piping - no joins. Deviation may result in an incorrectly displayed dewpoint.**

	Nylon Ø 6mm	Nylon Ø 8mm	PTFE Outer Ø 4mm Inner Ø 2mm (1mm wall section)
BAS HL 050 - HL 070	720mm (6 x)	350mm (1 x)	1200mm (1 x)
BAS HL 075 - HL 085	850mm (6 x)	570mm (1 x)	1200mm (1 x)

### Procedure

- Cut new Ø 6mm & Ø 8mm piping based upon lengths shown in table above
- Make note of the piping identification number on each length of Ø 6mm piping and where each pipe is connected
- Ensure each length of new piping has a corresponding identification number
- At the 5/2 control valves - Disconnect the 6 x Ø 6mm pipes feeding the 2 x inlet cylinders and 1 x exhaust cylinder
- At the control air filter inlet - Disconnect the Ø 8mm control air feed pipe
- Remove the 4 retaining screws attaching the backplate to the Breathing Air Purifier
- Carefully rotate the backplate 180 degrees and re-attach the backplate to Breathing Air Purifier using 2 of the existing retaining screws
- Connect new length of Ø 8mm pipe between the control air filter inlet & Breathing Air Purifier control air feed point on inlet casting
- Connect the new lengths of Ø 6mm piping to 5/2 control valves, ensuring the identification labels and piping configuration matches those used originally (see image).
- Replace Ø 4mm PTFE hygrometer piping with a longer, single length of Ø 4mm PTFE.

### Normally Open Valve Configuration

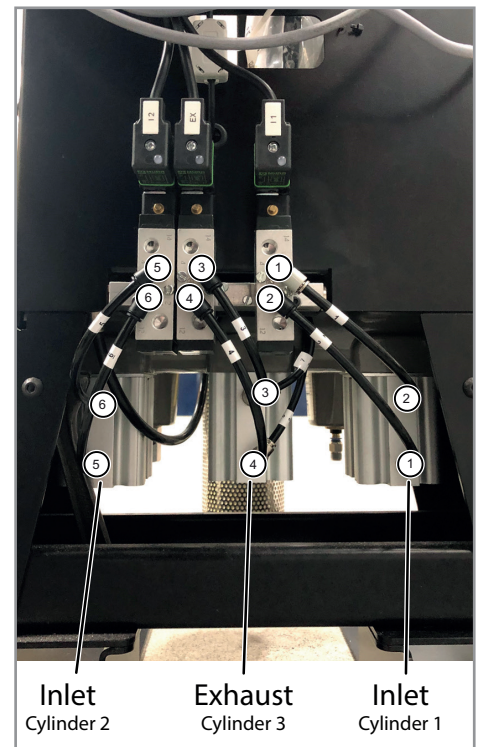

Standard Rear Panel  
(Rear View)



Side Mounted Rear Panel  
(Front View)



Side Mounted Rear Panel  
(Side View)



Side Mounted Rear Panel  
(Rear View)

## Securing the Breathing Air Purifier

Mounting holes are provided in the feet of the Breathing Air Purifier. Once the Breathing Air Purifier has been positioned in its final location ensure that it is securely fixed in place using M15 fixing bolts.

## Attach the Exhaust Silencer

The Breathing Air Purifier is supplied with an exhaust silencer. If the Breathing Air Purifier is to be located in a noise sensitive area, exhaust air can also be remotely piped away. If the exhaust is to be piped away then a minimum pipe size of 50mm (2 ins) should be used initially, expanding to larger diameter the longer the piping run becomes. As a rule of thumb a minimum bend radius of four times the radius of the pipe should be employed. Failure to pipe away correctly results in back pressure (indicated by a minimal pressure on the off-line pressure gauge) which prevents full regeneration of the off-line bed and results in loss of dewpoint.

## Setting the Purge Air Volume

The volume of purge air required by the Breathing Air Purifier must be set up during commissioning and is based upon the minimum pressure into the Breathing Air Purifier during operation.

### Purge Air Volume Setting Procedure

Before setting the purge air volume, fully close the Adjustable Purge Valve (ref 3 on diagram right) and ensure that the screwdriver slot is aligned with the number 12 on the purge dial.

Setting the purge air volume requires turning of the adjusting screw a number of full turns from fully closed, then fine tuning with partial turns to a numbered position on the dial.

Obtain the minimum operating pressure at the Breathing Air Purifier inlet and use the table below to identify the number of full turns and partial turns required.

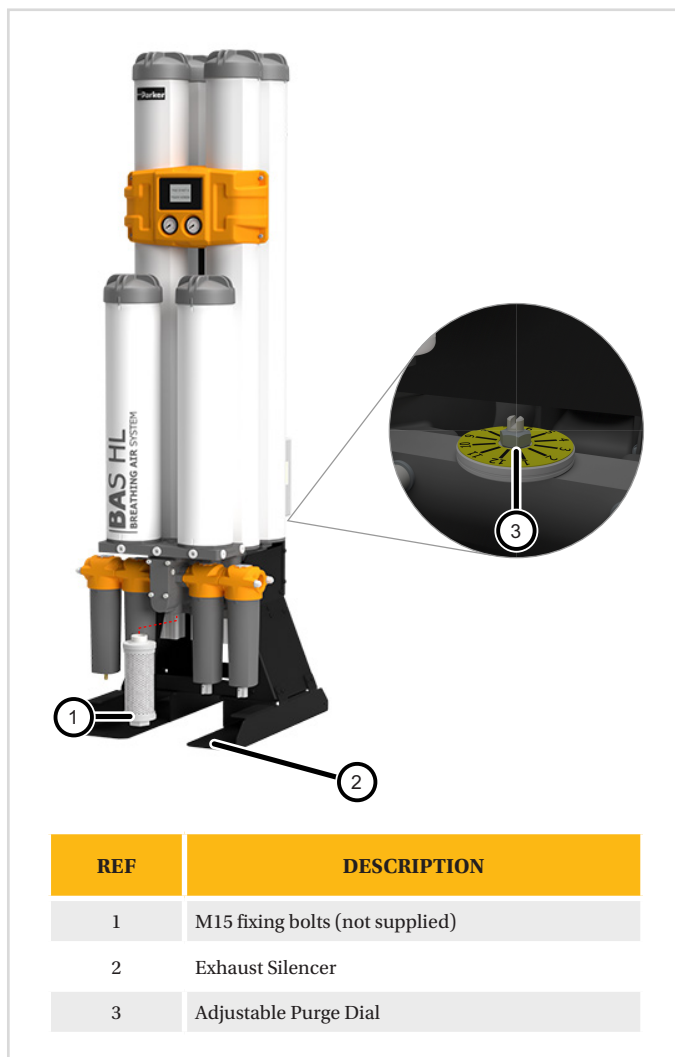

BAS	PURGE FLOW		DIAL SETTING	PRESSURE (Bar g)												
	(m <sup>3</sup> /hr)	(L/m)		4	5	6	7	8	9	10	11	12	13	14	15	16
HL 050	11	183	Full Turns	6	5	5	4	4	4	3	3	3	3	3	3	3
			+ dial No.	6	10	1.5	8.5	4.5	1.5	11.5	9.5	7.5	5.5	4.5	3.5	2.5
HL 055	14	233	Full Turns	6	6	6	5	5	4	4	4	4	3	3	3	3
			+ dial No.	11	7.5	1.5	7	2	10	6.5	4	1	11	9.5	8	7
HL 060	18	300	Full Turns	7	7	6	6	6	5	5	5	4	4	4	4	4
			+ dial No.	4.5	0	9	6	2	8.5	4.5	0.5	9	6.5	4.5	2.5	1.5
HL 065	22	367	Full Turns	7	7	7	6	6	6	6	5	5	5	4	4	4
			+ dial No.	8.5	4.5	1.5	10.5	8	5.5	2	9.5	5	2	11	8.5	7
HL 070	30	500	Full Turns	8	7	7	7	7	7	6	6	6	6	6	5	5
			+ dial No.	4	11.5	8	5	2	0	10	8.5	7	5	1.5	10	8
HL 075	37	617	Full Turns	8	8	8	7	7	7	7	7	6	6	6	6	6
			+ dial No.	9.5	4	0.5	9.5	7	4.5	3	1	11	9.5	8	7	5
HL 080	44	733	Full Turns	9	8	8	8	7	7	7	7	7	7	7	6	6
			+ dial No.	3	9	4.5	1.5	10.5	8	6	4.5	3	1.5	0	10.5	9
HL 085	60	1000	Full Turns	10	9	9	8	8	8	8	7	7	7	7	7	7
			+ dial No.	3	7	2	9	6	3	1	11	9	7.5	6.5	5	3.5

### Important Note:

Failure to correctly set purge during commissioning will seriously affect Breathing Air Purifier performance, placing the user at serious risk, causing damage to the adsorbent beds and invalidating the BAS HL warranty.

# ELECTRICAL INSTALLATION



A fully qualified electrical engineer must undertake all field wiring and electrical work in accordance with local regulations.

During installation and commissioning, the controller must be connected to a suitable power supply and configured using the dip switches found on the main control board.

If using any of the additional functions, these should also be connected at this time.

**Important Note:** Some additional features also require activation using the DIL switches found on the main control board.

## Breathing Air Purifier Electrical Supply

The Breathing Air Purifier can be connected to an electrical supply in the range of 85V-265V / 1ph / 50Hz or 60Hz and should be connected in accordance with local wiring regulations.

### Important Note:

The supplied ferrite (Part No. 74271222) must always be fitted to the incoming supply cable and as close as possible to the unit. Loop the cable next to the cable grommet and fit ferrite within the loop, covering two turns of the cable. (see drawing)

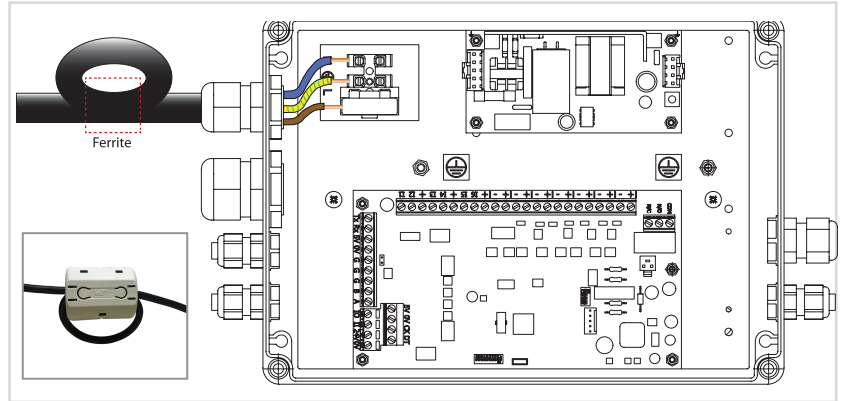



## Commissioning – Controller Setup Basic Installation

Before operating the Breathing Air Purifier, the following settings must be checked and if required be reconfigured to match the requirements of the installation:

### Configure “Dewpoint setpoint”

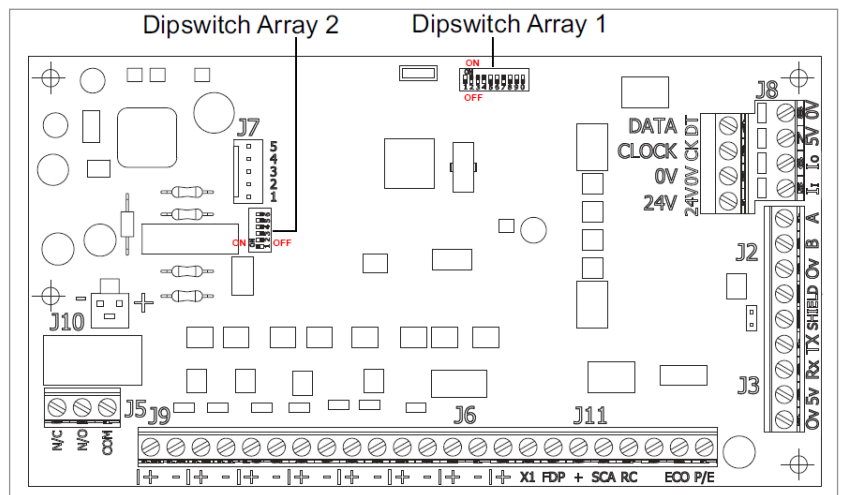
- For BAS HL, the control board will be factory set to deliver a -40°C outlet dewpoint.
- This setting will also configure the Dewpoint Alarm Set Point.
- A confirmation check of Dipswitch Array 2, DIL Switch 5 & DIL Switch 6 should be carried out by the commissioning engineer to ensure the dewpoint configuration is correctly set.



DIPSWITCH ARRAY (2)		
DIL SWITCH	FUNCTION	Switch Positions
5	Dewpoint Setpoint	
6	Dewpoint Setpoint	-40°C

DEWPOINT SET POINT	DEWPOINT ALARM SET POINT
-40°C (-40°F)	-20°C (-4°F)

## Inlet Valves Configuration (N/C - Normally Open)

- For safety, the default factory setting for BAS HL inlet valves is Normally Open
- This configuration should not be altered.
- A confirmation check of Dipswitch Array 1, DIL Switch 7 should be carried out to confirm Normally Open configuration.

DIPSWITCH ARRAY (1)			
DIL SWITCH	FUNCTION	OFF	ON
7	Valve Configuration	N/O	-

- A confirmation check of the piping should also be carried out - see image below

### Normally Open Valve Configuration

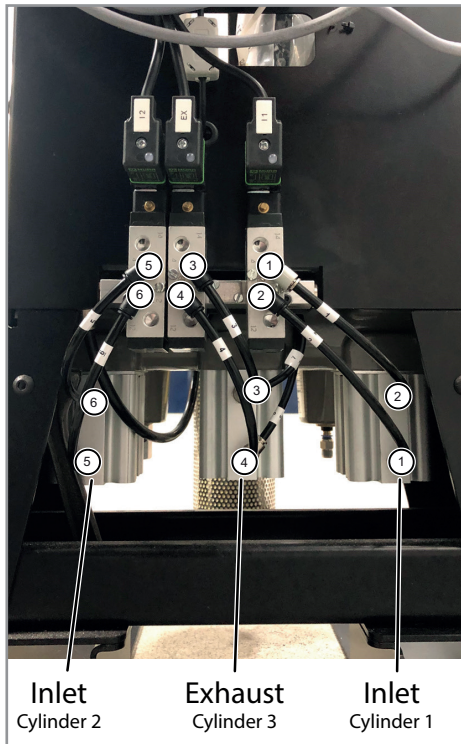

Always ensure the equipment is in BAS mode before use - check colour display screen for BAS symbol during first powerup.

### Configure Temperature Units to be displayed

- Default factory setting is °C. To show °F on the display, reconfigure Dipswitch Array 2, DIL Switch 3 as shown:

DIPSWITCH ARRAY (2)			
DIL SWITCH	FUNCTION	OFF	ON
3	Temperature Units	°C	°F



## Purge Economy Connection

Purge economy can only operate if the Breathing Air Purifier is installed directly after the compressor AND before an air receiver. Under no circumstances should purge economy be connected if there is an upstream, wet air receiver as this will saturate the desiccant bed, lose dewpoint, damage adsorption beds, risk user safety and invalidate the BAS HL warranty.

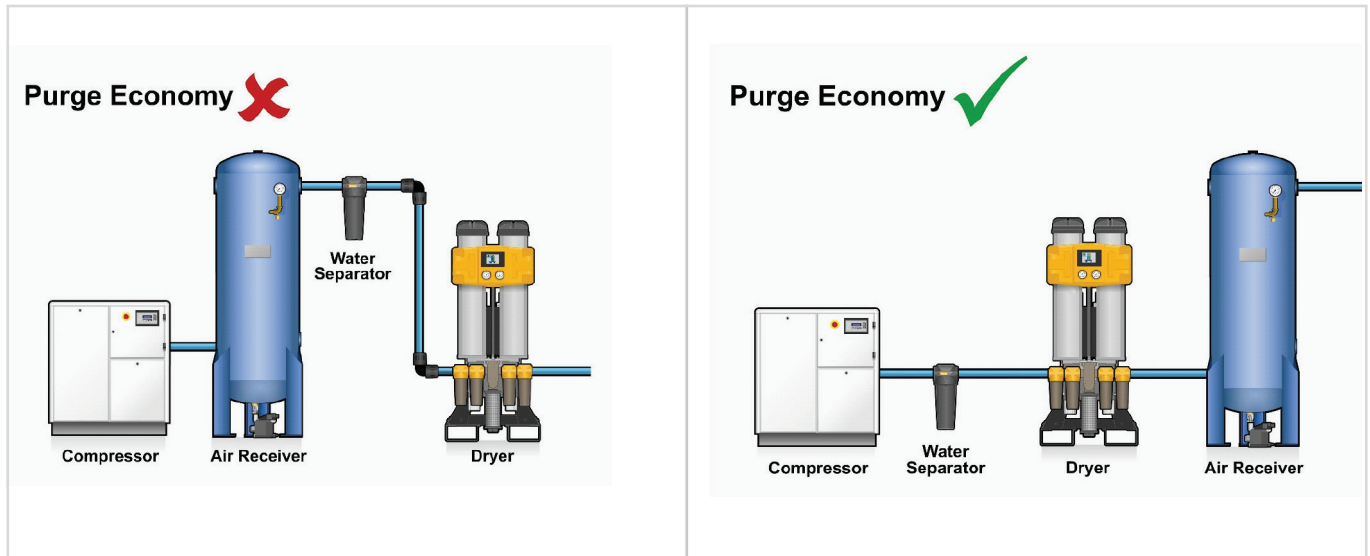

Purge economy requires a wired connection to the air compressor and relies on the compressor being fitted with a relay that will change state as the compressor switches between “on load” and “off load”.

### At the Compressor

- Identify the On Load / Off Load Relay
- Determine which terminal connection on the relay is open when the compressor is on load and closes when the compressor is off load
- This terminal and the common terminal of the relay will be used to form a digital switch.
- A 2-core cable will be required between the compressor relay and the Breathing Air Purifier.

### At the Breathing Air Purifier

- The Breathing Air Purifier control board supplies the 24V DC required to operate the Purge Economy Function.
- Connect one core of the cable from the “+” on the Breathing Air Purifier control board to the connection on the relay that is closed when the compressor goes off load.
- Connect the other core of the wire between the common connection on the relay and the P/E connection on the control board.

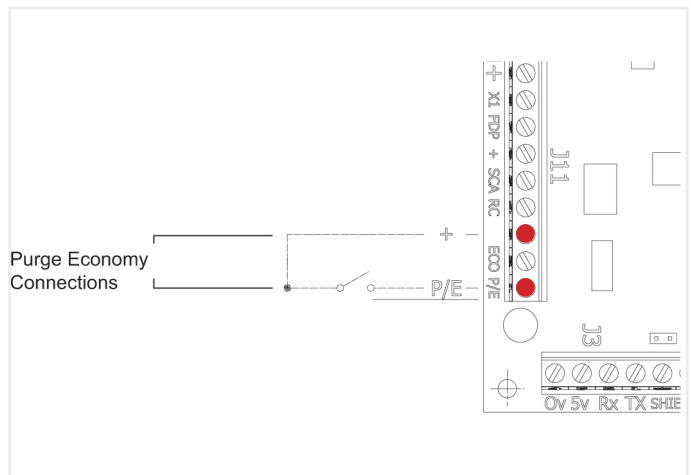

## Purge Economy Operation

### Compressor On Load

As the compressor is operating, the relay connection is open and the Breathing Air Purifier will be operating normally, drying the compressed air.

### Compressor Off Load

When the air compressor reaches its set operating pressure and goes off load, the relay in the compressor will close.

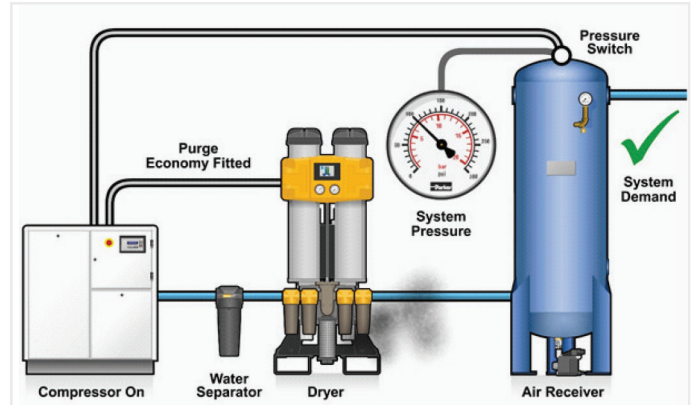

This completes the circuit, supplying 24VDC to the P/E (Purge Economy) terminal, activating the purge economy mode.

When purge economy is activated:

The Breathing Air Purifier purge economy mode will be factory set as mode 2 (**default mode**) and should not be changed. In mode 2 (**default mode**), the Breathing Air Purifier immediately closes the exhaust valve to repressurise the off-line column then stops the cycle.

With the exhaust valve closed, no purge air is consumed, saving energy & money.

The active inlet valve will remain energised (open). The fault relay(s) and spare output(s) will remain energised.



The purge economy icon will be visible on the display.

Once the system pressure drops due to air demand, the compressor re-starts.

The compressor relay contact will open, removing the 24V DC from the Purge Economy terminal.

The normal drying cycle will now be resumed.

## Remote Alarm Connection – General Fault Alarm

The BAS HL Breathing Air Purifier controller includes a general fault alarm used to indicate power loss, dewpoint alarm or dewpoint sensor failure.

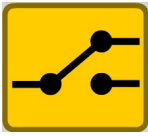

When the general fault alarm is active, an icon will be visible on the display.

The general fault alarm is linked to a relay providing volt free contacts: Normally Closed (N/C), Normally Open (N/O), and a Common (Com)

These contacts are rated 24Vdc and 230Vac @ 1A and can be used for remote alarm indication. The user can select to use either N/C & Com or N/O & Com to create a circuit should an alarm event occur.

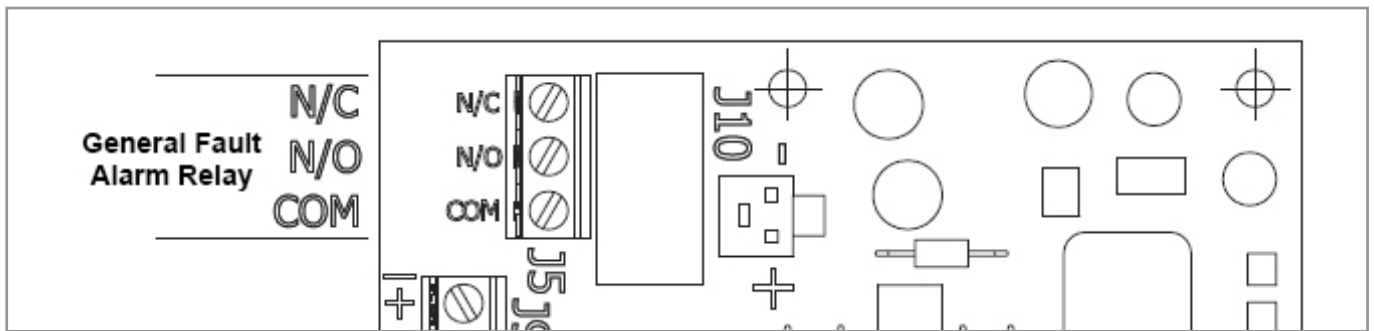

## Remote Alarm Connection Operation

Upon the application of power to the Breathing Air Purifier and under normal Breathing Air Purifier operation, the general fault alarm relay will be energised, changing the states of the N/C & N/O contacts.

POWER ON / NO ALARM
N/C & Com – Open Circuit
N/O & Com – Closed Circuit

Should the dewpoint alarm be activated, a dewpoint sensor fault be detected, or a power loss occur, the relay will de-energise, changing the state of the N/C & N/O contacts.

POWER LOSS / ALARM ACTIVATED
N/C & Com – Closed Circuit
N/O & Com – Open Circuit

## Remote Alarm Connection - Dedicated Dewpoint Alarm

The BAS HL Breathing Air Purifier controller includes the ability to connect a dedicated dewpoint alarm relay that will activate only if a dewpoint alarm occurs. This function requires the connection of an additional relay (not supplied) and activation by a trained engineer using the ADS service software.

Once activated via the ADS service software, the dewpoint alarm functionality is removed from the generic fault relay and assigned to the dedicated dewpoint alarm output.

The connection to the control board is used to energise the additional alarm relay (not supplied) and is rated at 3-30W@24VDC

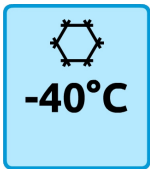
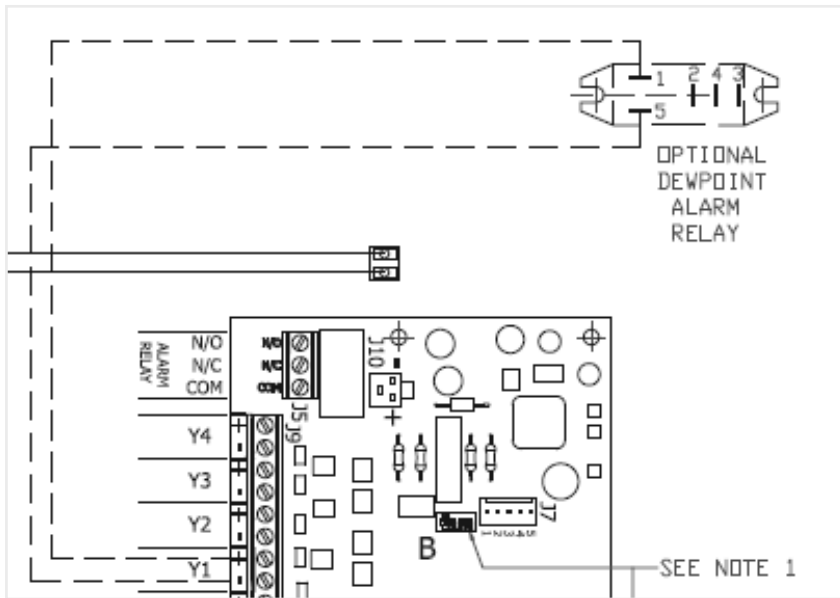

On the display screen, a blue box and background around the dewpoint icon and outlet dewpoint value indicates when the Breathing Air Purifier is operating within normal parameters and delivering a dewpoint less than or equal to the dewpoint setpoint.



Should the outlet dewpoint of the Breathing Air Purifier be higher than the dewpoint setpoint, a dewpoint alarm is activated.

This is identified by the normally blue background around the dewpoint icon changing to a yellow background.

With the dedicated dewpoint alarm relay fitted and enabled, the general fault alarm relay icon will not be shown.

The dedicated dewpoint alarm relay will changed state (de-energised), the general fault alarm relay will not change state (it will remain energised).

## 4-20mA Dewpoint Retransmission

The BAS HL Breathing Air Purifier controller includes a 4-20mA analogue output which is used for the retransmission of the Breathing Air Purifier dewpoint. Recommended cable: 0.75mm<sup>2</sup> twisted screened cable not exceeding 30m in length.

The tables below highlight the type of dewpoint sensor fitted to BAS HL & sensor accuracy.

RANGE	PRESSURE DEWPOINT
BAS HL	Hygrometer

DEWPOINT SENSOR TYPE	PRESSURE DEWPOINT MEASUREMENT RANGE	ACCURACY	CHANGE SENSOR EVERY
Hygrometer	-100°C to +20°C PDP	+/- 2°C	12 Months

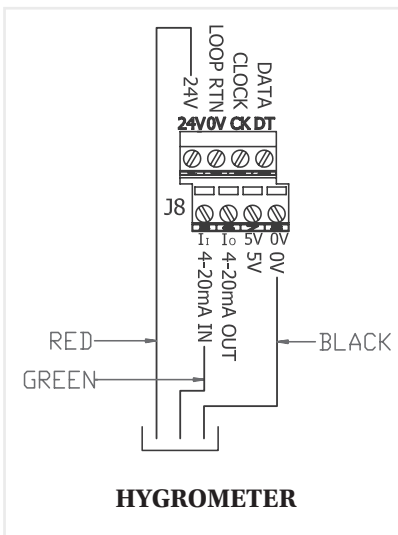

Hygrometer connection to BAS HL controller PCB.

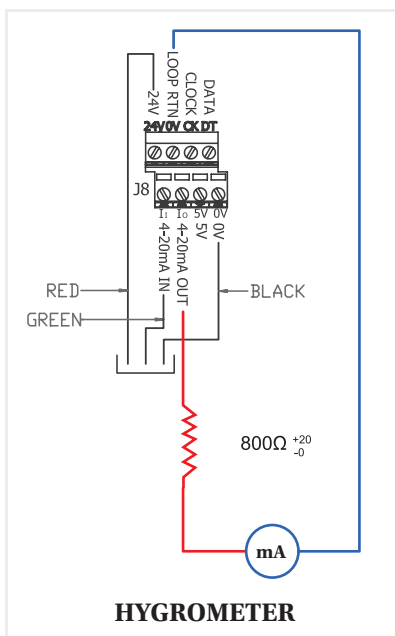

An 800Ω (+20 Ω / -0 Ω) resistor will be required in series in the loop circuit.

## Using the 4-20mA Signal

The calculation below is used to interpret the 4-20mA signal from the Hygrometer.

### Hygrometer 4-20 mA output Dewpoint Calculation

PARKER DEWPOINT SENSOR																	
Current mA	4	5	6	7	8	9	10	11	12	13	14	15	16	17	18	19	20
PDP °C	-100	-93	-85	-78	-70	-63	-55	-48	-40	-33	-25	-18	-10	-3	5	13	20

$$\text{Dewpoint} = ((\text{mA} - 4) \times 7.5) - 100$$

example:

measured value = 12mA

$$((12 - 4) \times 7.5) - 100 = -40$$

measure value = 14mA

$$((14 - 4) \times 7.5) - 100 = -25$$

## MODBUS connectivity

The BAS HL Breathing Air Purifier controller includes an RS485 port for MODBUS communication with a remote system using the MODBUS RTU protocol. All connections should be made to the 3 terminal block connections as shown below.

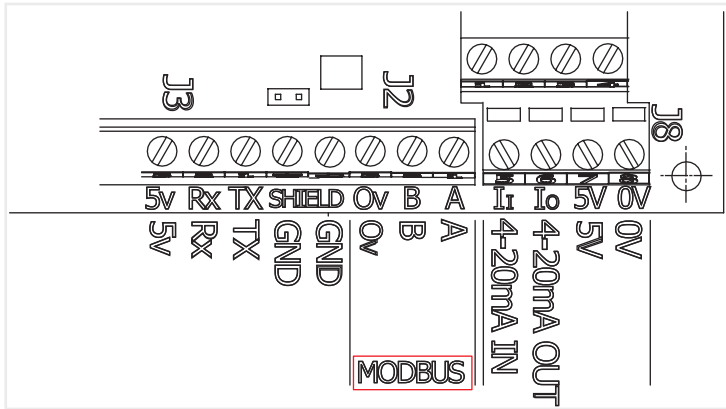

### Recommended Cable Size / Length

TWISTED PAIR SCREENED CABLE RECOMMENDED CABLE SIZE	MAX RECOMMENDED CABLE LENGTH
0.5mm <sup>2</sup> - 0.75mm <sup>2</sup>	500m [1650 ft]
0.75mm <sup>2</sup> - 1.0mm <sup>2</sup>	1000m [3300 ft]

The cable screen should be terminated at the terminal marked 0V. It is suggested that only the controller end of the screen is connected to earth.

### Default MODBUS Settings

Each unit (master & slaves) on the MODBUS network must have matching communication settings and a unique unit identification (ID). The default settings for the BAS HL controller are shown below.

TWISTED PAIR SCREENED CABLE RECOMMENDED CABLE SIZE	
Baud Rate	19200
Number of Data Bits	8
Parity	Even
Number of Stop Bits	1
Modbus Unit ID (Node)	55

The parameters for baud rate, data bits, parity, stop bits and unit ID can all be changed by a trained service engineer using the Parker ADS service software.



- When connected, the MODBUS icon will be shown on the display
- This also includes the MODBUS Unit ID (Node) number (default ID of 55 shown)

## MODBUS Strings

HOLDING NUMBER REGISTER	HOLDING REGISTER DESCRIPTION FUNCTION CODE 1	DETAILS
0		
1	Dewpoint Alarm	0: Reset 1: Active
2		
3	Inlet A	0: De-energised 1: Energised
4	Inlet B	0: De-energised 1: Energised
5	Exhaust	0: De-energised 1: Energised
6		
7		
8	Fault relay	0: De-energised (Alarm) 1: Energised
9		

HOLDING NUMBER REGISTER	HOLDING REGISTER DESCRIPTION FUNCTION CODE2	DETAILS
0	External Input: Purge Economy	0: De-asserted 1: Asserted
1	External Input: ECO	0: De-asserted 1: Asserted
2	External Input: Remote Stop	0: De-asserted 1: Asserted
3	External Input: SCA	0: De-asserted 1: Asserted
4	External Input: Filter DP High	0: De-asserted 1: Asserted
5	Unused	
6	DIP1-1: Service Timer Carbon	0: Reset 1: Active
7	DIP1-2: Service Timer Filter	0: Reset 1: Active
8	DIP1-3: Service Timer Desiccant	0: Reset 1: Active
9	DIP1-4: Cycle 1 (6 minute) Select	0: Reset 1: Active
10	DIP1-5: Cycle 2 (4 minute) Select	0: Reset 1: Active
11	DIP1-6: Cycle 3 (Custom) Select	0: Reset 1: Active
12	DIP1-7: Inlet Valve Configuration (on Remote Stop)	0: Energised 1: De-energised
13	DIP1-8: Remote Stop Enable	0: Disabled 1: Enabled
14	DIP1-9: Purge Setting Mode	0: Disabled 1: Enabled
15	DIP1-10: Service Timer FBP	0: Reset 1: Active
16	DIP2-1: Dewpoint Sensor Enable	0: Disabled 1: Enabled
17	DIP2-2: Dewpoint Sensor Select	0: I2C Sensor 1: 4-20mA Sensor
18	DIP2-3: Temperature Units	0: Deg C 1: Deg F
19	DIP2-4: Moisture Override Enable	0: Disabled 1: Enabled
20	DIP2-5: ECO Setpoint 1	0: -40 C 1: -20 C
21	DIP2-6: ECO Setpoint 2	0: Custom 1: -70 C

## MODBUS Strings Continued..

HOLDING NUMBER REGISTER	HOLDING REGISTER DESCRIPTION FUNCTION CODE 3	DETAILS
0	Software Version	
1	Graphics Version	
2	Run Time (Seconds)	
3		
4	ECO(DDS) Time (Seconds)	
5		
6	Calculated ECO(DDS) %	
7		
8	Display connection Status	0: Not Connected 1: Connected
9	Dew Point	
10	System Status 1	Bit 0: Dewpoint Alarm Bit 1: Dewpoint Sensor Open Circuit Bit 2: Dewpoint Sensor Short Circuit Bit 3: Not Defined Bit 4: Not Defined Bit 5: Not Defined Bit 6: Not Defined Bit 7: Carbon Hours Warning Bit 8: Filter Hours Warning Bit 9: Desiccant Hours Warning Bit 10: Catalyst Hours Warning Bit 11: Carbon Hours Alarm Bit 12: Filter Hours Alarm Bit 13: Desiccant Hours Alarm Bit 14: Catalyst Hours Alarm Bit 15: Invalid DIP Switch Settings
11	System Status 2	Bit 0: Remote Stop Mode Active Bit 1: Purge Economy Mode Active Bit 2: Purge Setting Mode Active Bit 3: Filter DP Alarm Active Bit 4: SCA Alarm Active Bit 5: Unused Bit 6: Dewpoint Sensor Fault Bit 7: I2C Sensor Fault Bit 8: I2C Magic Number Fault Bit 9: I2C Sensor Overrange Fault Bit 10: BAS Mode Active Bit 11: BAS Mode Config Fault Bit 12: Unused Bit 13: Unused Bit 14: Unused Bit 15: Unused
12	ADS Config: Hygrometer Minimum Output	Range: -120C to +40C
13	ADS Config: Hygrometer Range	Range: 50 to 150
14	ADS Config: Startup Dewpoint Alarm Delay	Range: 0 to 240 minutes
15	ADS Config: Dewpoint Fault Time Delay Minutes	Range: 0 to 60 minutes
16	ADS Config: Custom Dewpoint Alarm offset	Range: -120C to + 120C
17	ADS Config: Moisture Override Period	Range: 0 to 240 minutes
18	ADS Config: Moisture Override Half Cycles	Range: 0 to 10

HOLDING NUMBER REGISTER	HOLDING REGISTER DESCRIPTION FUNCTION CODE 3	DETAILS
19	ADS Config: Custom EST Setpoint	Range: -120C to 0C
20	ADS Config: Service Interval (Filter)	500 to 30,000Hours
21	ADS Config: Inlets N/O On Standby	0: Off 1: On
22	ADS Config: Separate Dewpoint Alarm Output	0: Off 1: On
23	ADS Config: Selected Cycle	0: 6 mins 1: 4 mins 2: Custom
24	ADS Config: Moisture Override Cycle Number	0: Disabled >0 Active (No. MO Cycles)
25		
26	IADS Config: IST Sensor Bias	
27	ADS Config: MODBUS Baud Rate	Range: 9600, 19200 or 38400 Baud
28	ADS Config: MODBUS Parity	Range: 0 (None), 1 (Odd), 2 (Even)
29	ADS Config: MODBUS Stop Bits	Range: 1 or 2
30	ADS Config: Custom Cycle Side A Exhaust On Time	Range: 0 to 1800s
31	ADS Config: Custom Cycle Side A Off Time	Range: 0 to 1800s
32	ADS Config: Custom Cycle Side A Exhaust Off Time	Range: 0 to 1800s
33	ADS Config: Custom Cycle Side B Exhaust On Time	Range: 0 to 1800s
34	ADS Config: Custom Cycle Side B Off Time	Range: 0 to 1800s
35	ADS Config: Custom Cycle Side B Exhaust Off Time	Range: 0 to 255
36	ADS Config: Modbus Address	Range: 0 to 255

# Changing MODBUS communication Settings Via ADS Service Software

## Important Note:

After changing any parameters, the control board must be power cycled (Power off / Power On) for the changes to be accepted.

To change the baud rate on the BAS HL Breathing Air Purifier it is necessary to connect the Breathing Air Purifier to a PC using the Parker ADS service software to communicate with the control board.

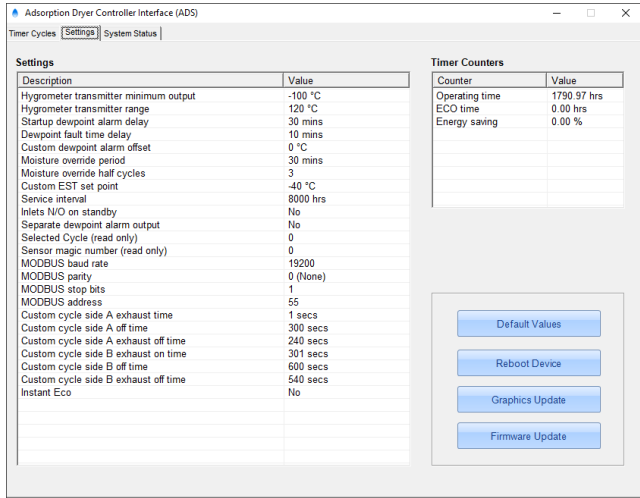

Once the Breathing Air Purifier is connected and the ADS software started, navigate to the SETTINGS tab.

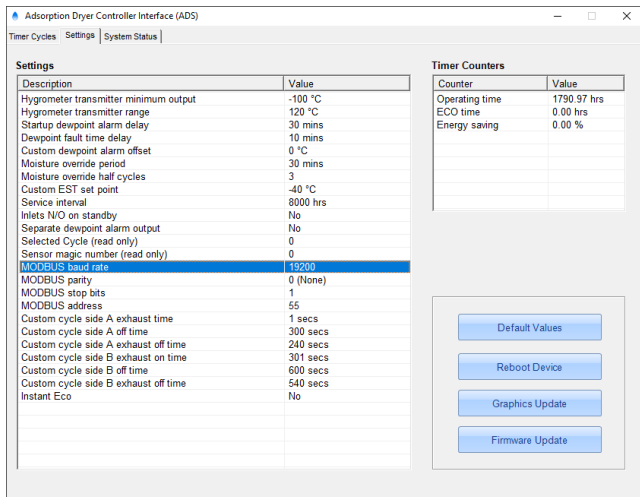

Left click on 'MODBUS baud rate'.

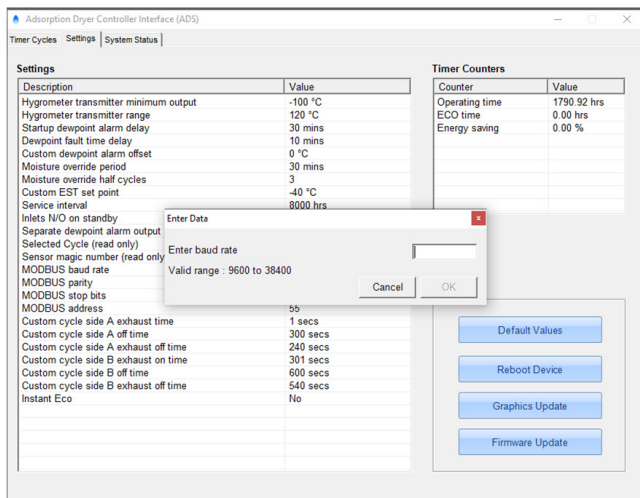

This will open a second window which will allow you to change the baud rate to match that of the MODBUS system.

The settings for MODBUS Parity, MODBUS Stop Bits and MODBUS Address (Unit ID or Node) are selected and changed in the same way to match the MODBUS system parameters.

# BAS HL OPERATION

# OVERVIEW OF OPERATION

BAS HL purification systems are based around a heatless adsorption dryer and associated pre filtration and post filtration.

The BAS HL adsorption dryers is designed for the reduction of water vapour and CO<sub>2</sub> only and therefore requires pre-treatment of the incoming compressed air to operate correctly and protect the adsorbent desiccant bed. BAS HL pre filtration consists of a general purpose coalescing filter and a high efficiency coalescing filter for the treatment of solid contaminants (atmospheric particulate, rust, pipescale, micro-organisms) and aerosols (oil and water). Should liquid water or liquid oil be present at the inlet of the BAS HL, a liquid separator (OIL-X Grade WS) will also be required to protect the pre filtration.

The heatless adsorption dryer of BAS HL operates on the Pressure Swing Adsorption (PSA) principle and consists of two identical drying columns (referred to as Column 1 & Column 2). Each column contains cartridges filled with adsorbent (desiccant) material.

During operation, one column will be used to dry the incoming process air and reduce the levels of CO<sub>2</sub> whilst the opposite column is being regenerated and readied for use.

Heatless adsorption dryers use a small proportion of the dry process air known as purge air to regenerate the desiccant material. Purge air is expanded to atmospheric pressure (where it becomes even drier) and is passed over the off-line desiccant bed where it strips the moisture and CO<sub>2</sub> from the desiccant material. The columns will be swapped periodically (referred to as “changeover”) to ensure a constant supply of dry air is always available downstream.

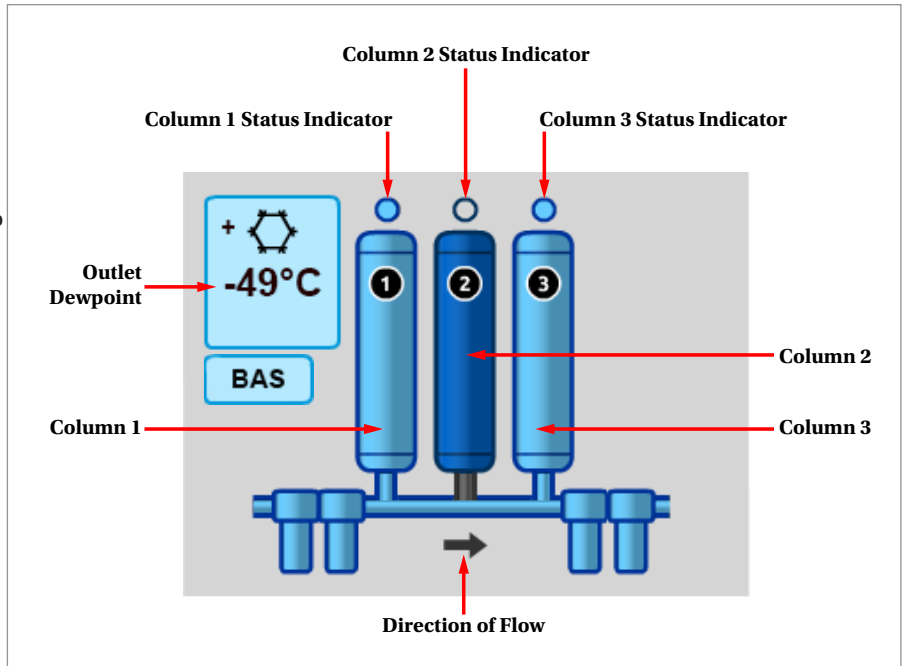

After drying, compressed air is passed through column 3 which contains an activated carbon cartridge for the reduction of oil vapour and a catalyst stage for the catalisation of carbon monoxide (CO) into carbon dioxide (CO<sub>2</sub>).

Upon exiting Column 3, the compressed air is passed through a pair of dry particulate filters (general purpose and high efficiency) before exiting the unit.

BAS HL	DESICCANT MATERIAL USED
≤-40°C	100% Activated Alumina

# BAS HL OPERATION

## BAS HL Breathing Air Purifier Cycle Times and Operation

BAS HL Breathing Air Purifiers are designed to use two drying columns to deliver a constant outlet dewpoint.

A full cycle is the time it takes the Breathing Air Purifier to fully utilise the desiccant material in both columns. A full cycle on BAS HL Breathing Air Purifiers operating at full load = 360 Seconds (6 minutes).

A ½ cycle is the time it takes the Breathing Air Purifier to fully utilise the desiccant material of a single column. A ½ cycle on BAS HL Breathing Air Purifiers operating at full load = 180 Seconds (3 minutes).

### Drying of the Compressed Air and reduction of CO<sub>2</sub> (3 Minutes on Fixed Timing Cycle)

Having passed through the coalescing pre filters, the inlet valves direct the incoming process air through one of the two dryer columns containing the desiccant cartridges (column 1 in the example image).

When a column is drying compressed air, it is referred to as the 'on-line' column.

Compressed air enters the desiccant cartridge of the on-line column at the bottom and flows upwards where it is in contact with the bed of adsorbent desiccant material. Water vapour and CO<sub>2</sub> in the compressed air is adsorbed by the desiccant material.

Standard drying cycle is 180 seconds.

As the dried compressed air reaches the top of the desiccant cartridge, it changes direction, flowing down the column around the desiccant cartridge and into the inlet of Column 3.

### Regeneration of the Off-line Desiccant Material

#### Exhausting or De-pressurisation

At the same time compressed air is directed through the on-line column to be dried, the opposite column (column 2 in the image) will be undergoing regeneration (referred to as the "off-line" column). To regenerate the off-line column, the pressurised compressed air it contains must first be vented to atmosphere. To do this the Breathing Air Purifier controller will open the exhaust valve, allowing the compressed air contained within the off-line column to exit via the exhaust valve and silencer. This process of exhausting the air is known as de-pressurisation. A check valve (ball) prevents the process air from flowing down the off-line column.

#### Regeneration (2 ½ Minutes)

Once the off-line column has been de-pressurised, the exhaust valve will remain open for the regeneration cycle. Expanded, dry purge air taken from the process air will flow up the outside of the desiccant cartridge to the top of the column then down the inside of the cartridge, across the adsorbent desiccant bed for 150 seconds (2 ½ minutes), stripping the moisture and CO<sub>2</sub> from the desiccant material as it flows out of the Breathing Air Purifier via the open exhaust valve and silencer.

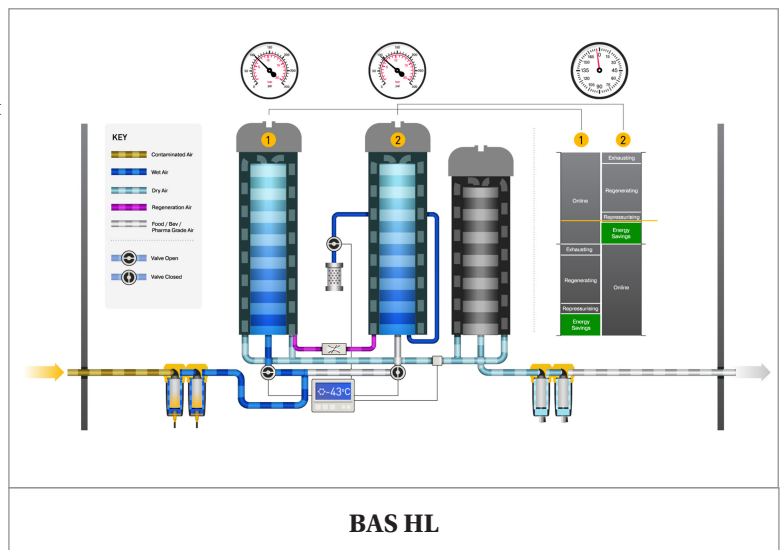

**Important Note: Purge air volume must be set up during commission to supply the correct amount of purge air required for efficient regeneration. Refer to page 20 for purge volume setting.**

**Re-pressurisation (30 seconds)**

After 150 seconds (2 ½ minutes) of regeneration, the exhaust valve will close, and the purge air will re-pressurise the off-line column. This is to ensure there is no drop in downstream pressure as the drying columns change over. Re-pressurisation time is 30 seconds.

**Changeover**

Following re-pressurisation, the controller will instruct the Breathing Air Purifier to “changeover”. On a fixed timing cycle, drying & regeneration is 180 seconds (3 minutes). Using the inlet valves, the process air flow will be redirected over to the newly regenerated desiccant bed, allowing the wet adsorbent material of the opposite column to be regenerated.

**BAS HL Breathing Air Purifier Timing Cycles**

All adsorption dryers have a standard fixed cycle to ensure drying / regeneration / changeover is continuous. The diagram below illustrates the fixed timing cycle of a BAS HL Breathing Air Purifier.

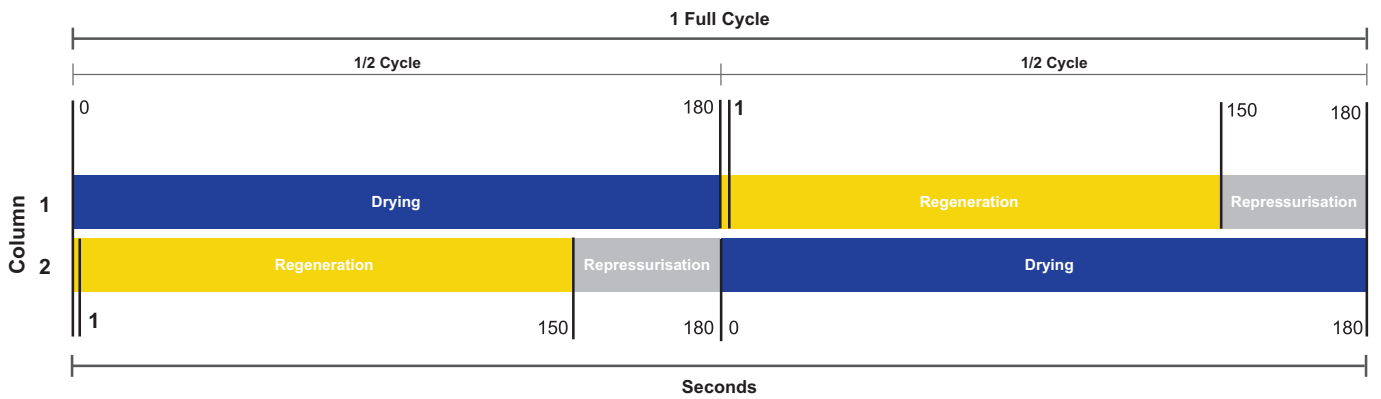

**1 Full Cycle = 360 Seconds (6 minutes)**

**½ Cycle = 180 Seconds (3 minutes)**

# OPERATING THE EQUIPMENT

## BAS HL Electronic Controller & Display

BAS HL Breathing Air Purifiers are supplied as standard with an electronic control system which includes a dewpoint sensor and colour display.

Breathing Air Purifier Model	Pressure Dewpoint
	-20°C / -40°C (-4°F / -40°F)
BAS HL	Hygrometer

In addition to providing the basic control of the Breathing Air Purifier, the BAS HL controller also provides additional functionality which includes:

- Purge Economy
- Remote Alarm Connection
- Dedicated dewpoint alarm
- MODBUS connectivity
- 4-20mA Dewpoint Retransmission

### Important Notes:

- **The above functions all require additional external connections**
- **Always ensure the equipment is in BAS mode before use - check colour display screen for BAS symbol**

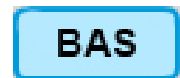

# OPERATING THE Breathing Air Purifier

## Displays and Indicators

Standard BAS HL Breathing Air Purifiers are fitted with a 3.45" colour TFT display (Please note - this is not a touchscreen). Below is an example of the basic display format.

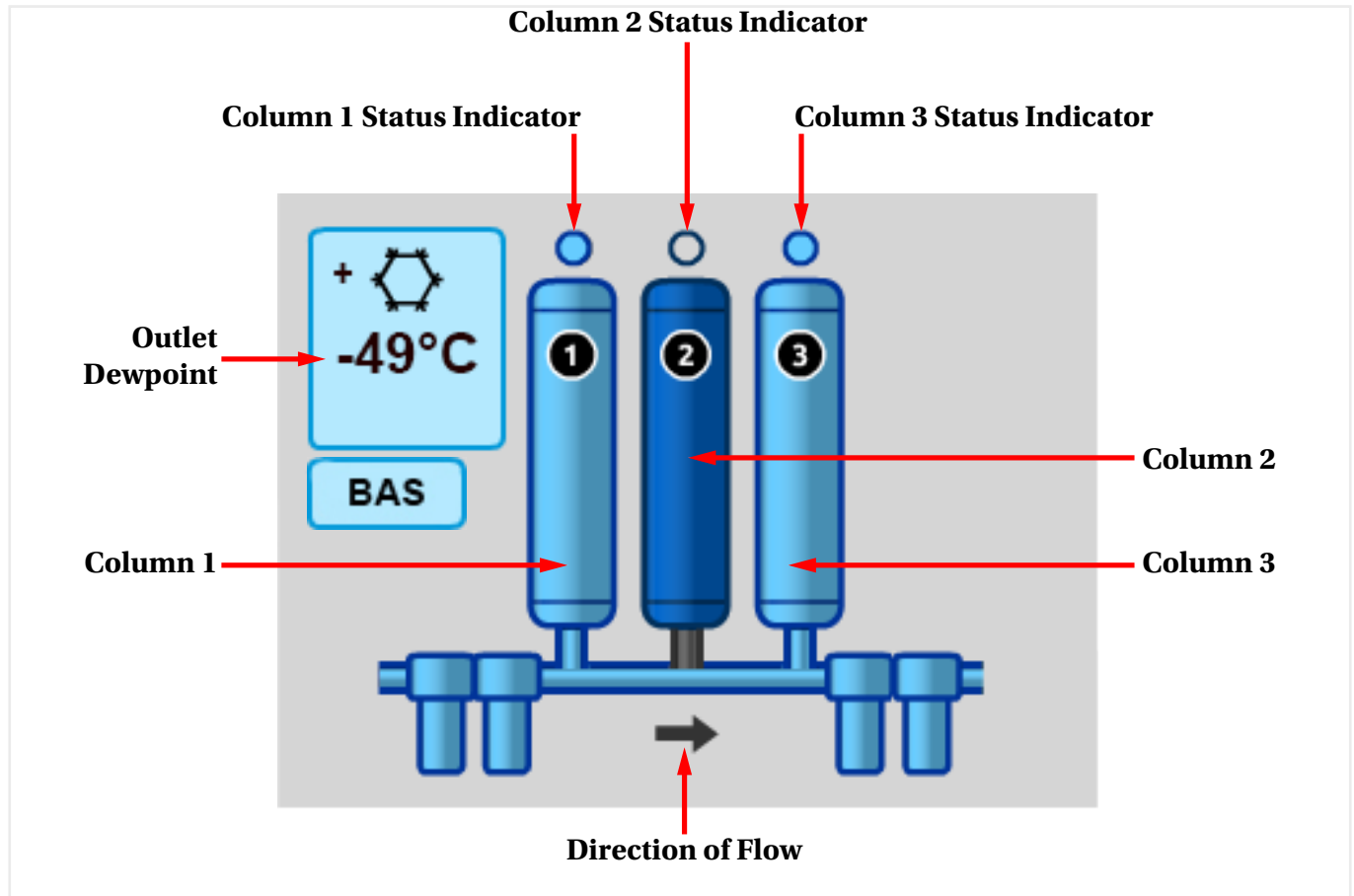







Always ensure the equipment is in BAS mode before use - check colour display screen for BAS mode icon.

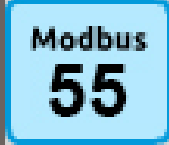

## Column Status Indicators

	Dark blue ring with light blue fill (Light Blue Column) indicates that the column is online.		Dark grey ring with a dark grey fill (Dark Green Column) indicates that the column is in Economy mode.
	Dark blue ring with no fill (Dark Blue Column) indicates that the column is regenerating.		Dark grey ring with a light grey fill (Light Grey Column) indicates that the column is in Standby.
	Dark grey ring with a gradient fill (Dark Grey Column) indicates that the column is re-pressurising.		Dark grey ring with a dark grey fill (Dark Grey Column) Indicates that the column is fully pressurised during Purge Economy Mode

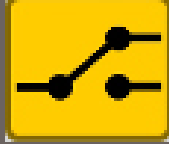
## Screen Icons

	<p>"BAS" = Indicates controller has been set up for a BAS Breathing Air Purifier</p> <p>Do not operate the equipment if this icon is not displayed on the screen</p>		<p>Flashing "+" = Breathing Air Purifier heartbeat, used to identify controller and screen are communicating</p>
	<p>"Numerical value in °C or °F" = Real time Breathing Air Purifier Outlet Pressure Dewpoint</p>		<p>MODBUS ICON = Indicated Modbus is connected</p> <p>Numerical Value = Modbus ID (Node)</p>
	<p>"ERR" = Dewpoint sensor error</p> <p>Breathing Air Purifier will operate in fixed timing cycle when a dewpoint sensor error is detected</p> <p>A general alarm fault will also be activated</p>		<p>General Fault Alarm</p> <p>Indicates when the General Fault Alarm Relay has been activated</p>
	<p><b>Dewpoint Alarm - General Fault Relay</b></p> <p>Yellow Background = Dewpoint Alarm</p> <p>General Fault Alarm Relay will be activated and General Fault Alarm icon will also be present on screen</p>		<p><b>Dewpoint Alarm - Dedicated Dewpoint Fault Relay</b></p> <p>Yellow Background = Dewpoint Alarm</p> <p>No General Fault Alarm icon will be displayed</p> <p>Dedicated Dewpoint Alarm Relay will be activated</p>

# Breathing Air Purifier Start Up & Shut Down Procedures

## Breathing Air Purifier Start Up

1. Ensure that the isolation valves on the inlet and the outlet of the Breathing Air Purifier are closed.
2. Switch on the Breathing Air Purifier electrical supply and verify that the display illuminates.
3. Slowly open the isolation valve on the inlet of the Breathing Air Purifier and verify that there are no leaks.
4. Test the condensate drains of the filters by manually opening and closing the float drain (warning - pressurised air or condensate will be present) and ensure they are discharging correctly into a suitable collection vessel.
5. Slowly open the outlet isolation valve to allow the system to pressurise. Do not open the valve fully until the down stream system has reached the correct operating pressure.

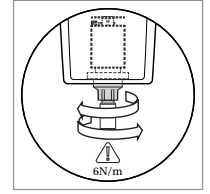

The Breathing Air Purifier is designed for continuous use and, once running, requires no further operator intervention.

## Display - Start Up

When applying power to the Breathing Air Purifier, the controller display will show the software version number for 10 seconds.



The main display will appear after 10 seconds.

### Important Notes:

- Always ensure the equipment is in BAS mode before use - check colour display screen for BAS mode icon.
- Do not operate the equipment if this icon is not displayed on the screen

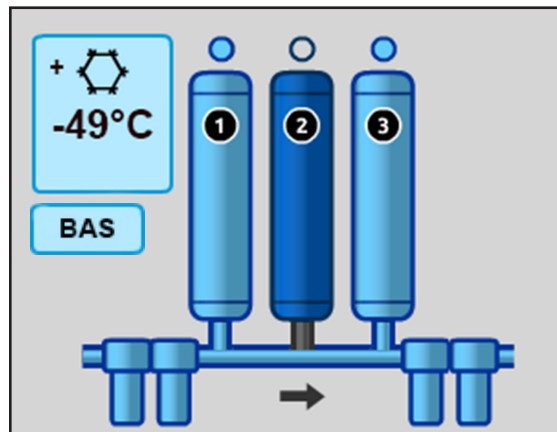

### Important Notes:

#### Start up column

At first start-up from commissioning, the Breathing Air Purifier will automatically start drying on column 1. If the Breathing Air Purifier has been operated previously, the controller will remember its last known position from power off and resume from where it left off in the cycle.

#### Dewpoint Display

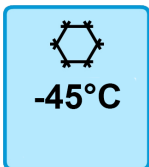

When the Breathing Air Purifier is operating, the outlet dewpoint will be shown in real time in the upper left corner of the display.

## Breathing Air Purifier Shut Down

To shut down and depressurise the Breathing Air Purifier:

1. Turn OFF the Breathing Air Purifier electrical supply at the isolator.
2. Close the isolation valve on the outlet followed by the isolation valve on the inlet.
3. Slowly open the drain ball valve on the outlet filter to depressurise the Breathing Air Purifier.

**Important Note:** A small amount of air may be trapped between the inlet isolation valve and the Breathing Air Purifier inlet. This can be removed by manually opening and closing the inlet filter float drain.

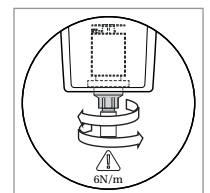

### Display During A Typical Drying Cycle

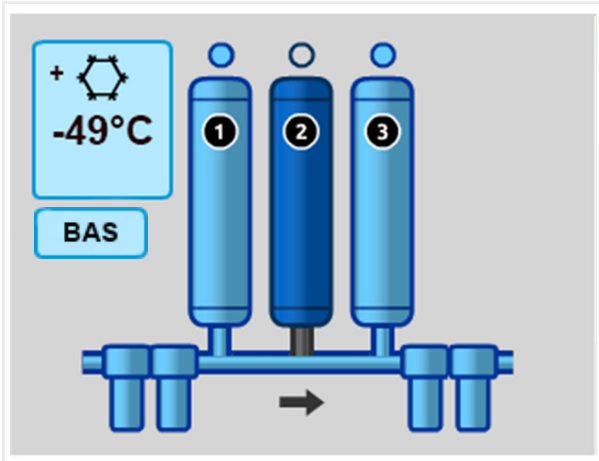

VALVE	VALVE STATUS	COLUMN STATUS			COLUMN PRESSURISED
Inlet 1	Open	Column 1	On-line	Drying	Yes
Exhaust	Open	-			
Inlet 2	Closed	Column 2	Off-line	Regenerating	No

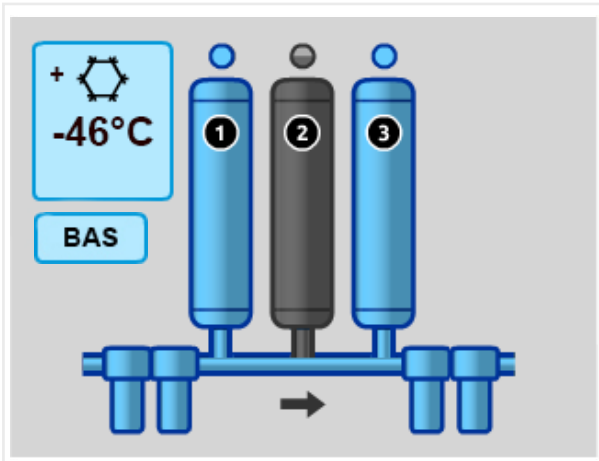

VALVE	VALVE STATUS	COLUMN STATUS			COLUMN PRESSURISED
Inlet 1	Open	Column 1	On-line	Drying	Yes
Exhaust	Closed	-			
Inlet 2	Closed	Column 2	Off-line	Repressurising	Yes

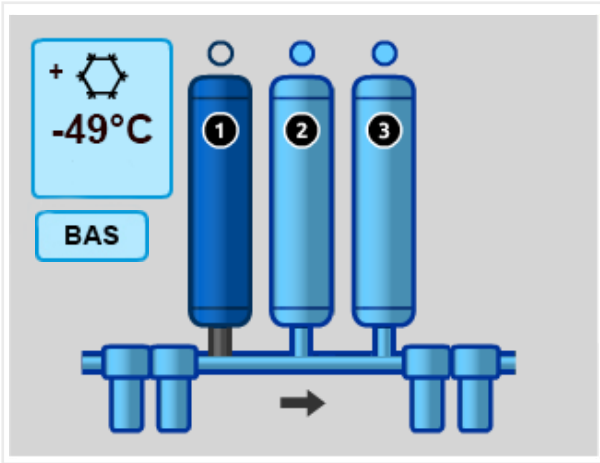

VALVE	VALVE STATUS	COLUMN STATUS			COLUMN PRESSURISED
Inlet 1	Closed	Column 1	Off-line	Regenerating	No
Exhaust	Open	-			
Inlet 2	Open	Column 2	Off-line	Drying	Yes

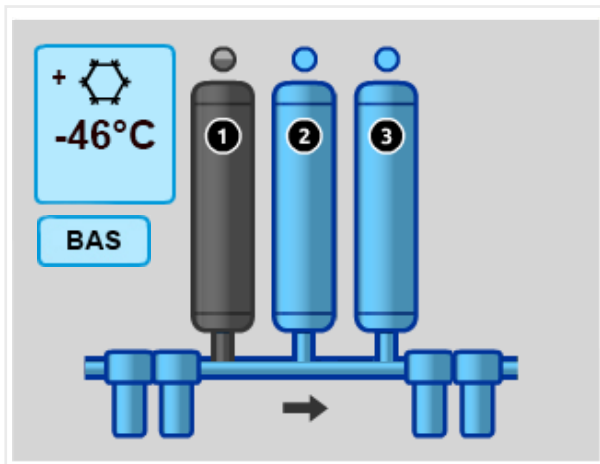

VALVE	VALVE STATUS	COLUMN STATUS			COLUMN PRESSURISED
Inlet 1	Closed	Column 1	Off-line	Repressurisation	Yes
Exhaust	Closed	-			
Inlet 2	Open	Column 2	On-line	Drying	Yes

## Important Notes:

### Dewpoint Alarm Delay at Start Up

Following application of power there is a dewpoint alarm delay of 30 minutes (customisable by a trained engineer using the Parker ADS service software). During the alarm delay period, should the Breathing Air Purifier outlet dewpoint be worse than the dewpoint alarm setpoint, the alarm relay will not be triggered.

DEWPOINT SET POINT SELECTED (BREATHING AIR PURIFIER OUTLET DEWPOINT)	DEFAULT DEWPOINT ALARM SET POINT	Dewpoint Alarm Delay at Start-up	Dewpoint Alarm Fault Relay Activation Delay
-40°C (-40°F)	-20°C (-4°F)	30 minutes	10 minutes

### Dewpoint Alarm Fault - Activation Delay

Once the dewpoint alarm delay at start-up period has passed, any dewpoint fault is subject to an alarm relay activation delay.

Should the Breathing Air Purifier outlet dewpoint be worse than the dewpoint alarm setpoint, the controller will not activate the general alarm relay (or dewpoint alarm relay if fitted and activated) unless the outlet dewpoint fault is longer than 10 minutes (default value is customisable by a trained engineer using the Parker ADS service software)

### BAS HL Display Icons - Alarm Activation

#### Dewpoint Alarm - General Fault Relay Activated

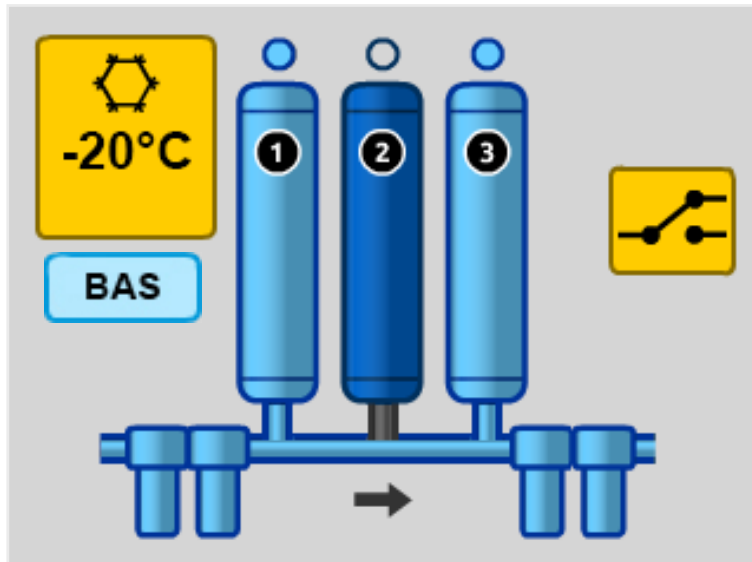

#### Dewpoint Alarm - Dedicated Dewpoint Relay Fitted and Activated

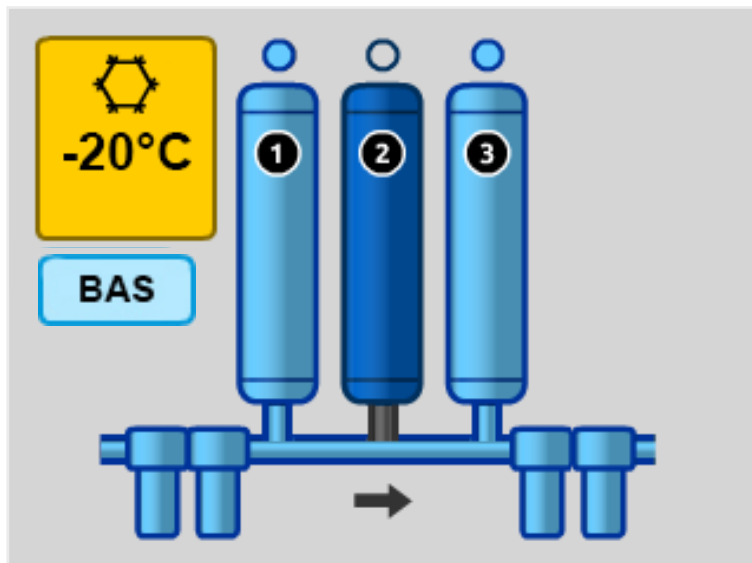

## BAS HL Display Icons

Yellow Filter - Static Spanner Image - Filter Service Due  
Yellow Filter - Flashing Spanner Image - Filter Service Overdue

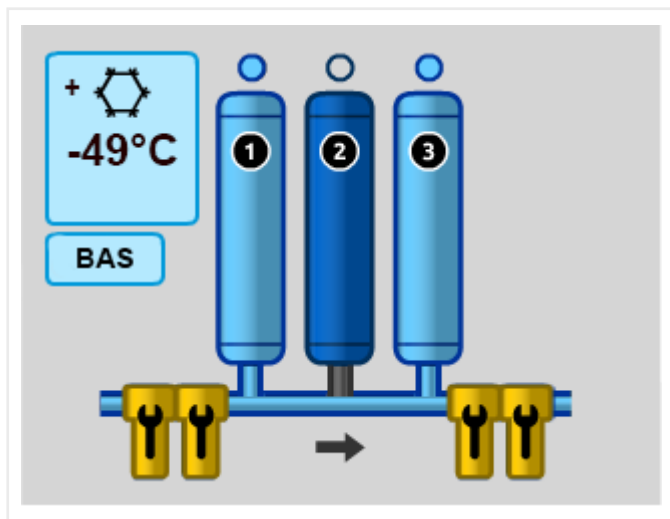

Yellow Breathing Air Purifier Columns - Static Spanner Image - Breathing Air Purifier Service Due  
Yellow Breathing Air Purifier Columns - Flashing Spanner Image - Breathing Air Purifier Service Overdue (BAS model shown)

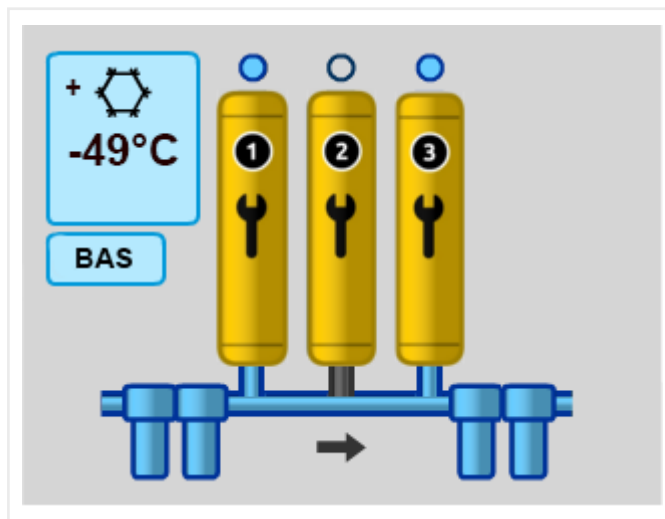

Yellow Filter and Breathing Air Purifier Columns - Static Spanner Image - Filter and Breathing Air Purifier Service Due  
Yellow Filter and Breathing Air Purifier Columns - Flashing Spanner Image - Filter and Breathing Air Purifier Service Overdue

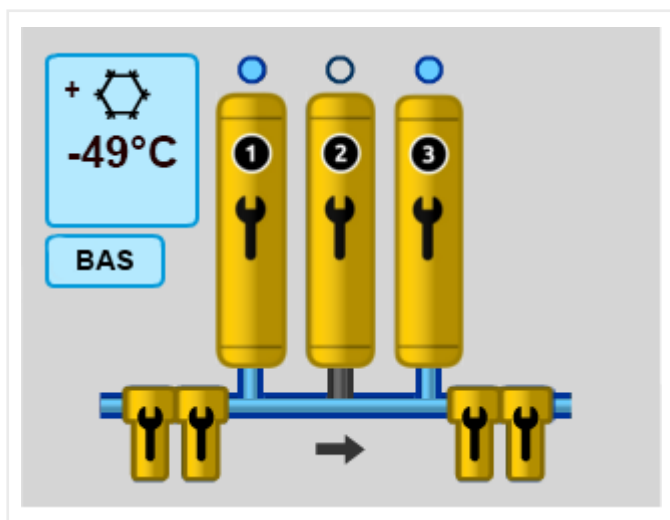













# PREVENTATIVE MAINTENANCE

# CLEANING

Clean the equipment with a damp cloth only and avoid excessive moisture around any electrical sockets. If required you may use a mild detergent, however do not use abrasives or solvents as they may damage the warning labels on the equipment.

# SERVICE INTERVALS

Description of Service Required		Service Recommended Every:						
Component	Operation	Daily	Weekly	3 Months	6 Months	12 Months	24 Months	60 Months
Breathing Air Purifier	Check POWER ON and STATUS / FAULT indicators.							
Breathing Air Purifier	Check for air leaks.							
Breathing Air Purifier	Check the pressure gauges during purging for excessive back pressure.							
Breathing Air Purifier	Check the condition of electrical supply cables and conduits.							
Breathing Air Purifier	Check for cyclic operation.							
Breathing Air Purifier	Replace the exhaust silencers.							
Filtration	Replace inlet / outlet / control air filter elements. Replace inlet filter / control air filter float drains.							
Breathing Air Purifier	Replace Parker Dewpoint Sensor or Dewpoint Hygrometer transmitter							
Breathing Air Purifier	Replace the outlet check ball							
Breathing Air Purifier	Replace the inlet valves (x 2), exhaust valve (x1) and 5/2 control valves							
Breathing Air Purifier	Replace the Catalyst Cartridges							
Breathing Air Purifier	Replace the Desiccant Cartridges.							
Breathing Air Purifier	Replace the Carbon Cartridges.							

## Key

	Check		Recommended Service
---	-------	---	---------------------

# PREVENTATIVE MAINTENANCE KITS - BAS HL

CATALOGUE NUMBER	DESCRIPTION	12	24	36	48	60	ORDER QTY
M12.FSK.9001	12 Month Filter Service Kit	✓	✓	✓	✓	✓	BAS HL 050 - BAS HL 055 (x1)
M12.FSK.9002	12 Month Filter Service Kit	✓	✓	✓	✓	✓	BAS HL 060 (x1)
M12.FSK.9003	12 Month Filter Service Kit	✓	✓	✓	✓	✓	BAS HL 065 (x1)
M12.FSK.9004	12 Month Filter Service Kit	✓	✓	✓	✓	✓	BAS HL 070 (x1)
M12.FSK.9005	12 Month Filter Service Kit	✓	✓	✓	✓	✓	BAS HL 075 (x1)
M12.FSK.9006	12 Month Filter Service Kit	✓	✓	✓	✓	✓	BAS HL 080 (x1)
M12.FSK.9007	12 Month Filter Service Kit	✓	✓	✓	✓	✓	BAS HL 085 (x1)
<b>24 Month Catalyst Service Kits</b>							
M24.CAT.9001	24 Month Catalyst Service Kit	✗	✓	✗	✓	✗	BAS HL 050 - BAS HL 060 (x1)
M24.CAT.9002	24 Month Catalyst Service Kit	✗	✓	✗	✓	✗	BAS HL 065 - BAS HL 070 (x1)
M24.CAT.9003	24 Month Catalyst Service Kit	✗	✓	✗	✓	✗	BAS HL 075 (x2)
M24.CAT.9004	24 Month Catalyst Service Kit	✗	✓	✗	✓	✗	BAS HL 080 - BAS HL 085 (x2)
<b>60 Month Desiccant Service Kits</b>							
M60.DSK.9001	60 Month Desiccant Service Kit	✗	✗	✗	✗	✓	BAS HL 050 (x1)
M60.DSK.9002	60 Month Desiccant Service Kit	✗	✗	✗	✗	✓	BAS HL 055 (x1)
M60.DSK.9003	60 Month Desiccant Service Kit	✗	✗	✗	✗	✓	BAS HL 060 (x1)
M60.DSK.9004	60 Month Desiccant Service Kit	✗	✗	✗	✗	✓	BAS HL 065 (x1)
M60.DSK.9005	60 Month Desiccant Service Kit	✗	✗	✗	✗	✓	BAS HL 070 (x1)
M60.DSK.9006	60 Month Desiccant Service Kit	✗	✗	✗	✗	✓	BAS HL 075 (x1)
M60.DSK.9007	60 Month Desiccant Service Kit	✗	✗	✗	✗	✓	BAS HL 080 (x1)
M60.DSK.9008	60 Month Desiccant Service Kit	✗	✗	✗	✗	✓	BAS HL 085 (x1)

# PM KIT CONENTS

## Every 12 months



CATALOGUE NO'S	DESCRIPTION	CONTENTS
M12.FSK.9001 M12.FSK.9002 M12.FSK.9003 M12.FSK.9004 M12.FSK.9005 M12.FSK.9006 M12.FSK.9007	Kit: 12 month service	Filter elements (x5) Filter Drains (x3) Silencer element (x1) Dewpoint sensor (x1) Outlet check valve (x1) Carbon Cartridge (x1)

## Every 24 months



CATALOGUE NO'S	DESCRIPTION	CONTENTS
M24.CAT.9001 M24.CAT.9002 M24.CAT.9003 M24.CAT.9004	Kit: 24 month service	Catalyst Cartridge(s) <i>models - BAS HL 050 - BAS HL 070 (x1)</i> <i>models - BAS HL 075 - BAS HL 085 (x2)</i>

## Every 60 months

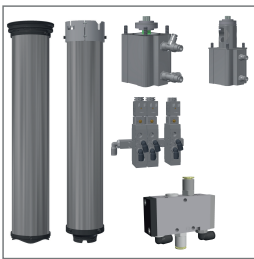

CATALOGUE NO'S	DESCRIPTION	CONTENTS
M60.DSK.9001 M60.DSK.9002 M60.DSK.9003 M60.DSK.9004 M60.DSK.9005 M60.DSK.9006 M60.DSK.9007 M60.DSK.9008	Kit: 60 month service	Desiccant cartridges Inlet and exhaust valves Control valves QRV valve

# TECHNICAL SPECIFICATION

# TECHNICAL SPECIFICATION

## Dryer Performance

DRYER MODEL	PRESSURE DEWPOINT (STANDARD)		ISO 8573-1:2010 CLASSIFICATION
	°C	°F	(STANDARD)
BAS HL	-40	-40	Class 1.2.0

## Technical Data

DRYER MODEL	MIN OPERATING PRESSURE		MAX OPERATING PRESSURE		MIN OPERATING TEMPERATURE		MAX OPERATING TEMPERATURE		MAX AMBIENT TEMPERATURE	
	BAR G	PSI G	BAR G	PSI G	°C	°F	°C	°F	°C	°F
BAS HL	4	58	16	232	5	41	50	122	55	131

## Flow Rates

DRYER MODEL	Pipe Size BSPP or NPT	INLET FLOW RATE			
		L/S	M3/MIN	M3/HR	CFM
BAS HL 050	1/2"	15	0.92	55	32
BAS HL 055	1/2"	19	1.17	70	41
BAS HL 060	1/2"	25	1.50	90	53
BAS HL 065	1/2"	31	1.84	110	65
BAS HL 070	3/4"	42	2.51	150	88
BAS HL 075	1"	51	3.09	185	109
BAS HL 080	1"	61	3.67	220	129
BAS HL 085	1 1/2"	83	5.01	300	177

Stated flows are for operation at 7 bar (g) (102 psi g) with reference to 20°C, 1 bar (a), 0% relative water vapour pressure. For flows at other pressures, apply the correction factors shown below.

## Product Selection & Correction Factors

For correct operation, compressed air dryers must be sized using the minimum pressure, maximum temperature and maximum flow rate of the installation. To select a dryer, first calculate the MDC (Minimum Drying Capacity) using the formula below then select a dryer from the flow rate table above with a flow rate equal to or above the MDC.

$$\text{Minimum Drying Capacity} = \text{System Flow} \times \text{CFIT} \times \text{CFAT} \times \text{CFP} \times \text{CFD}$$

### CFIT - Correction Factor Maximum Inlet Temperature

MAXIMUM INLET TEMPERATURE	°C	25	30	35
	°F	77	86	95
CORRECTION FACTOR		1.00	1.00	1.00

### CFAT - Correction Factor Maximum Ambient Temperature

MAXIMUM AMBIENT TEMPERATURE	°C	25	30	35	40	45	50
	°F	77	86	95	104	113	122
CORRECTION FACTOR		1.00	1.00	1.00	1.00	1.00	1.00

### CFP - Correction Factor Maximum Inlet Pressure

MAXIMUM INLET PRESSURE	BAR G	4	5	6	7	8	9	10	11	12	13	14	15	16
	PSI G	58	73	87	100	116	131	145	160	174	189	203	218	232
CORRECTION FACTOR		1.60	1.33	1.14	1.00	0.89	0.80	0.73	0.67	0.62	0.57	0.53	0.50	0.47

### CFD - Correction Factor Dewpoint

MAXIMUM INLET TEMPERATURE	°C	-40
	°F	-40
CORRECTION FACTOR		1.00

## Electrical Data

	DRYER MODEL							
	BAS HL 050	BAS HL 055	BAS HL 060	BAS HL 065	BAS HL 070	BAS HL 075	BAS HL 080	BAS HL 085
Supply Voltage (Standard)	85 - 265V 1PH 50/60Hz							
Supply Voltage (optional)	24V DC							

## Environmental Data

RELATIVE HUMIDITY	55%
IP RATING	IP55, indoor use only
POLLUTION DEGREE <sup>1</sup>	2
MAXIMUM ALTITUDE	800 m (2625) (ft)
NOISE	< 75 dB(A)

<sup>1</sup> Pollution Degree 2 indicates that in order for this equipment to operate safely, only non-conductive pollution (i.e. solids, liquids or ionised gases) or temporary condensation may be present within the environment.

# APPROVALS COMPLIANCE AND EXEMPTIONS

## Approvals

### Safety and Electromagnetic Compatibility

This equipment has been tested and complies with the following European Standards:

BS EN 60204-1:2006 (Including: Amendment1:2009) - Safety of machinery. Electrical equipment of machines. General requirements.

EN61326: 2006 - Electrical Equipment for Measurement, Control, and Laboratory use, EMC Requirements.

EN 55011:2009 (Including: Amendment1:2010) - Industrial, scientific and medical equipment. Radio-frequency disturbance characteristics. Limits and methods of measurement.

Generally in accordance with ASMEVIII Div 1 : 2010 + 2011a Addenda. AS/NZS 1715:2009

### 3rd Party Performance Verification

OIL-X Coalescing Filters tested in accordance with ISO12500-1 & ISO8573-4

OIL-X Dry Particulate Filters tested in accordance with ISO8573-4

BAS HL Breathing Air Purifiers have been tested in accordance with ISO7183 and proven to meet and exceed the requirements of:

- ISO 8573-1:2010 Class 1:2:0 (<0.003mg/m<sup>3</sup> for total oil)
- ISO 8573-1:2010 Class 1:2:1.
- EN 12021:2014 Respiratory Equipment - Compressed gases for breathing apparatus
- European Pharmacopoeia (Ph. Eur.) 10th Edition
- ANSI/CGA G-7.1-1989 Commodity Specification for Air - Seventh Edition, Grade D OSHA Breathing Air
- CSA Z180.1:19 Compressed breathing air and systems

Performance validation independently verified by Lloyds Register

## APPROVALS, ACCREDITATIONS AND ASSOCIATIONS



ISO9001:2000 ISO14001



## INTERNATIONAL APPROVALS



# BAS HL WEIGHTS AND DIMENSIONS

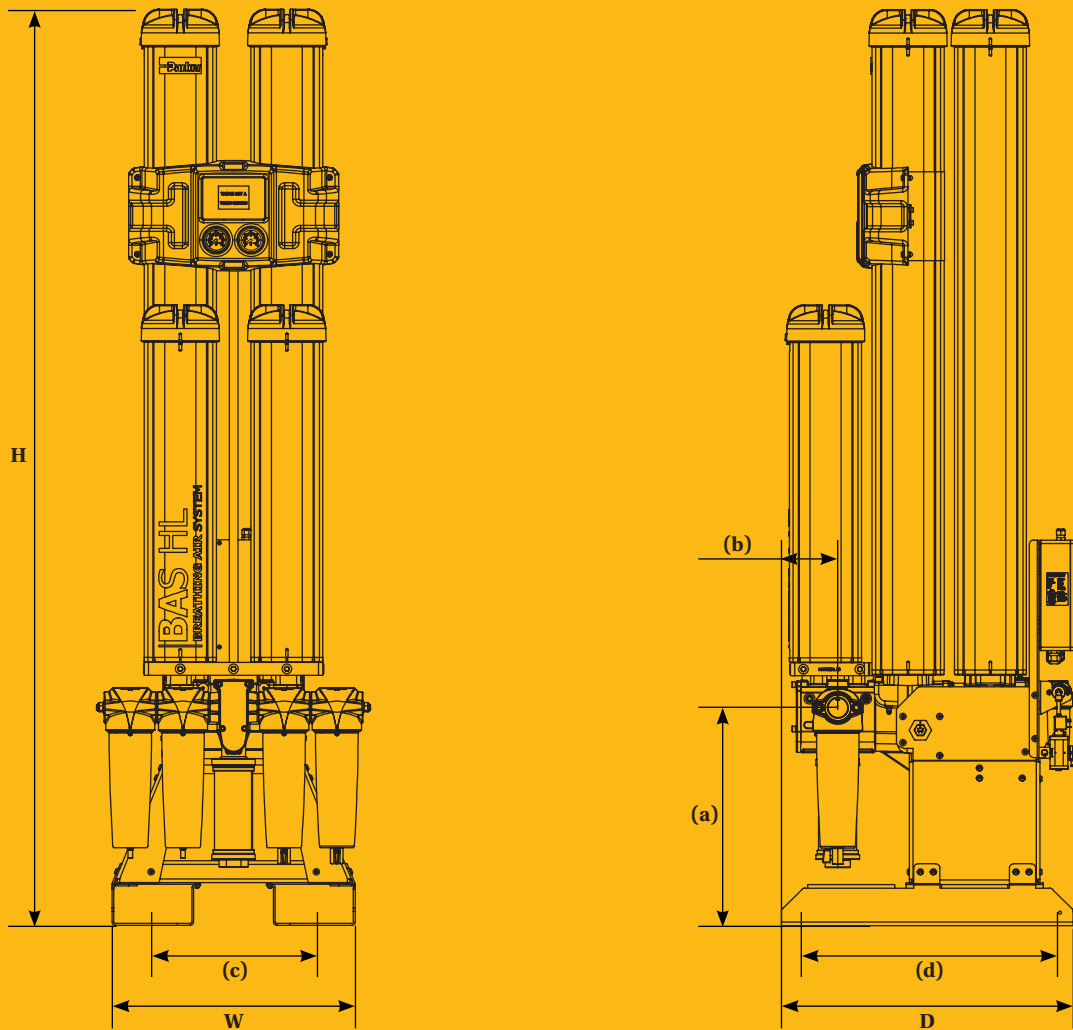

DRYER MODEL	DRYER DIMENSIONS														WEIGHT	
	H		W		D		(a)		(b)		(c)		(d)			
	MM	INS	MM	INS	MM	INS	MM	INS	MM	INS	MM	INS	MM	INS	KG	IBS
BAS HL 050	1133	44.6	559	22.0	490	19.3	416	16.4	96.5	3.80	371.3	14.62	410	16.14	92	203
BAS HL 055	1313	51.7	559	22.0	490	19.3	416	16.4	96.5	3.80	371.3	14.62	410	16.14	99	218
BAS HL 060	1510	59.4	559	22.0	490	19.3	416	16.4	96.5	3.80	371.3	14.62	410	16.14	109	240
BAS HL 065	1660	65.4	559	22.0	490	19.3	416	16.4	96.5	3.80	371.3	14.62	410	16.14	115	254
BAS HL 070	2020	79.5	559	22.0	490	19.3	416	16.4	96.5	3.80	371.3	14.62	410	16.14	138	304
BAS HL 075	1595	62.8	559	22.0	682	26.9	501	19.71	129	5.09	371.3	14.62	610	24.02	196	432
BAS HL 080	1745	68.7	559	22.0	682	26.9	501	19.71	129	5.09	371.3	14.62	610	24.02	220	485
BAS HL 085	2105	82.9	559	22.0	682	26.9	501	19.71	129	5.09	371.3	14.62	610	24.02	255	562

# TROUBLESHOOTING

In the unlikely event that a problem occurs on the equipment, this troubleshooting guide can be used to identify the probable cause and remedy.



## Warning

Troubleshooting should only be attempted by competent personnel. All major repair and calibration work should be undertaken by a Parker trained, qualified and approved engineer.

## Dewpoint Failure

A dewpoint failure will result in there being water in the downstream piping and equipment

PROBABLE CAUSE	REMEDY
The inlet parameters have changed.	If the inlet flow-rate or the inlet temperature have increased ensure that the filters and Breathing Air Purifier are re-sized accordingly. If the inlet pressure has changed ensure that the filters and Breathing Air Purifier are re-sized accordingly.
The condensate is not being drained.	Verify that all condensate drains are functioning correctly. Check that the drain hoses are free from kinks and obstructions. Ensure that the isolation valves on the drains are fully open.
The compressor is not functioning correctly.	Check the documentation supplied by the compressor manufacturer for troubleshooting guidance.
The compressor capacity has changed.	Ensure that the filters and Breathing Air Purifier are sized accordingly.
The after cooler is not functioning correctly.	Test that condensate drain is operating correctly. Check that the cooling water system is functioning correctly and that the water temperature is within specification (water cooled systems only). Ensure that the after cooler and dust filter (if fitted) are clean (air cooled systems only). Ensure that the fan is functioning correctly (air cooled systems only).
There is no wet air receiver fitted within the system.	Install a wet air receiver and drain within the system (if possible). Ensure there is adequate drainage on the piping prior to the Breathing Air Purifier pre-filtration. A water separator should also be installed before the Breathing Air Purifier pre-filtration to ensure removal of bulk liquid.
Filtration has not been correctly maintained.	If the element and float drain have been installed longer than 12 months ensure that they are both changed. Verify that the float drain is operating correctly.
The Breathing Air Purifier has been by-passed.	If a bypass line has been installed on the system ensure that it is closed. Use bypass filtration.
The regeneration column pressure within the Breathing Air Purifier is greater than 350mbar.	Contact a Parker approved service agent.
There is a fault with the Breathing Air Purifier timer.	Contact a Parker approved service agent.
There is a fault with the Breathing Air Purifier valves.	Contact a Parker approved service agent.
The desiccant is approaching the end of its useful life.	Contact a Parker approved service agent.

## Loss of Outlet Dewpoint

<p>Confirm loss of dewpoint</p>	<p>Check outlet dewpoint downstream of the Breathing Air Purifier with an external hygrometer.</p>	<p>If outlet dewpoint on external hygrometer does not match dewpoint on Breathing Air Purifier display - check sensor the Breathing Air Purifier dewpoint sensor</p>	
<p>Confirm Breathing Air Purifier sizing</p>	<p>Check sizing (Max inlet flow rate, Min inlet pressure, Max inlet temperature)</p>	<p>Sizing correct, continue below. Sizing incorrect, install correctly sized Breathing Air Purifier or correct inlet parameters.</p>	
<p>Confirm no liquid is present at inlet to coalescing filters</p>	<p>Check aftercooler drain operation. Check liquid separator drain operation. Check air receiver drain operation. Check condensate lines are not blocked &amp; condensate is flowing correctly.</p>	<p>Coalescing filters are not designed for liquid removal (water &amp; oil aerosols only). If upstream equipment drains are not operating correctly and / or condensate is not being discharged from these drains correctly, excessive liquid will be entering the inlet filters and overloading the Breathing Air Purifier, leading to loss of dewpoint If no wet air receiver is fitted in the compressed air system before the Breathing Air Purifier, an optional WS grade water separator should always be installed prior to the coalescing filters.</p>	
<p>Confirm pre-filtration drains are operating correctly</p>	<p>Check General Purpose Coalescing Filter Float Drain Operation Check High Efficiency Coalescing Filter Float Drain Operation Check condensate lines are not blocked &amp; condensate is flowing correctly. If an optional WS grade water separator is fitted, check float drain operation.</p>	<p>If the drains fitted to the Breathing Air Purifier pre filters (and optional WS if fitted) are not operating correctly and / or condensate is not being discharged correctly, excessive liquid will be entering the Breathing Air Purifier, resulting in loss of dewpoint.</p>	
<p>Confirm purge setting</p>	<p>Check purge has been set for the MINIMUM inlet pressure to the Breathing Air Purifier.</p>	<p>Purge is factory set for 6 bar g and must be reset on commissioning to the minimum inlet pressure into the Breathing Air Purifier. Incorrectly set purge will result in insufficient purge to regenerate the desiccant material, resulting in loss of outlet dewpoint or excessive purge resulting in insufficient compressed air downstream, dropping system pressure and potentially overloading the Breathing Air Purifier leading to loss of dewpoint</p>	
<p>Check Breathing Air Purifier is cycling correctly (all valves are functioning)</p>	<p>Check Breathing Air Purifier is cycling between each column Check the Breathing Air Purifier is depressurising when required Check the Breathing Air Purifier is purging when required Check the Breathing Air Purifier is repressurising when required</p>	<p>If Breathing Air Purifier does not changeover, ensure both inlet cylinders are operating correctly (check 5/2 valve operation, individual cylinder operation and seals) If Breathing Air Purifier does not depressurise, ensure exhaust valve is operating correctly (check 5/2 valve operation, exhaust cylinder operation and seals) If the pressure gauge for the column undergoing regeneration (purging) shows a pressure &gt;350mbar, ensure exhaust silencer is not blocked (check 5/2 valve operation, cylinder operation and seals) If Breathing Air Purifier does not repressurise, ensure exhaust valve is operating correctly (check 5/2 valve operation, cylinder operation and seals) If Breathing Air Purifier does not repressurise fully before changeover, ensure correct purge setting and check QRV valve operation</p>	<p>Normal Function Changeover Column A drying Exhaust valve open Column B depressurised Column B purging - no dP on gauges Exhaust valve closes Column B repressurises and reaches full line pressure before changeover After 3 minutes, if dewpoint &lt; setpoint, Breathing Air Purifier enters EST, ECO shown on screen Dewpoint set-point reached Changeover</p>
		<p>LED's illuminated on the solenoid plugs but Breathing Air Purifier fails to cycle correctly</p>	<p>Check when the LED is illuminated that 24VDC is at the output of the plug Check the condition of the spool valve for smooth movement.</p>

## Loss of Outlet Dewpoint Continued...

Check Parker Dewpoint Sensor	Check the Parker Dewpoint Sensor is clean	Remove any particulate with low pressure compressed air	
Check cartridge sealing	Check cartridge sealing on column showing low dewpoint Check cartridge sealing on column showing low dewpoint	Switch off Breathing Air Purifier once both columns have depressurised Depressurise Breathing Air Purifier Remove column top caps Remove cartridges Check cartridge seals are intact Check cartridge seals are in wave groove Reseat cartridges carefully Replace column top caps Introduce pressure slowly Restart Breathing Air Purifier Check dewpoint for recovery	
Check condition of outlet check valve ball	Check outlet check ball for deterioration / deformation	Switch off Breathing Air Purifier Depressurise Breathing Air Purifier Remove check valve ball cover plate Inspect ball for deterioration / deformation Replace if necessary Replace cover plate Introduce pressure slowly Restart Breathing Air Purifier Check dewpoint for recovery	
Check for back flow	Check a non return valve is installed at Breathing Air Purifier outlet	Check purge assembly for blockage & clean if necessary Check QRV for blockage and clean if necessary Check desiccant cartridge for signs of carbon dust	

## High Pressure drop

A high pressure drop will result in low pressure gauge readings or intermittent operation of the downstream equipment.

PROBABLE CAUSE	REMEDY
Filtration has not been correctly maintained.	If the element and float drain have been installed longer than 12 months ensure that they are both changed. Verify that the float drain is operating correctly.
The inlet parameters have changed.	If the inlet flow-rate has increased ensure that the filters and Breathing Air Purifier are re-sized accordingly. If the inlet temperature has increased verify that the filters are within specification. Ensure that the oil vapour removal filters and the Breathing Air Purifier are re-sized accordingly. If the inlet pressure has changed ensure that the filters and Breathing Air Purifier are re-sized accordingly. Contact Parker for details on particle counting and air quality air measurement.
The compressor is not functioning correctly.	Check the documentation supplied by the compressor manufacturer for troubleshooting guidance.
There is a pressure loss from the system.	Check for leaks in the piping and at connection points. Ensure that all drain cocks and pressure relief valves are closed. Check to see if the downstream flow-rate demand has increased.
The Breathing Air Purifier is not powered up.	Verify that the Breathing Air Purifiers power indicator is illuminated. If the Breathing Air Purifier is not powered check the isolator and circuit breaker.
An isolation valve is closed or partially closed.	Check the position of all isolation valves.

## Downstream air supply interrupted

An interruption of the air supply downstream will result is a rapid loss of system pressure and failure of the downstream equipment.

PROBABLE CAUSE	REMEDY
Filtration has not been correctly maintained. The compressor is not functioning correctly.	Check the documentation supplied by the compressor manufacturer for troubleshooting guidance.
There is a pressure loss from the system.	Check for leaks in the piping and at connection points.
The Breathing Air Purifier is not powered up.	Verify that the Breathing Air Purifiers power indicator is illuminated. If the Breathing Air Purifier is not powered check the isolator and circuit breaker. Check the Breathing Air Purifier fault indicators.

# UK Declaration of Conformity

EN

Parker Hannifin Manufacturing Limited GSFE  
Dukesway, Team Valley Trading Estate, Gateshead, Tyne & Wear, NE11 0PZ, UK  
Compressed Air Dryer

BASHL050, BASHL055, BASHL060, BASHL065, BASHL070, BASHL075, BASHL080, BASHL085

PE(S)R 2016 (as amended) SI 2016 No. 1105  
EE(S)R 2016 (as amended)  
ECR 2016 (as amended)

## Regulations

PE(S)R Generally in accordance with  
ASME VIII Div 1 : 2021

EE(S)R BS EN 61010-1 : 2010

## Standards used

ECR BS EN 61326-1 : 2013

**PE(S)R Assessment Route:** Module B + D

**PE(S)R Certificate Number** COV0912556/1

**PE(S)R Approved Body Number** Approval Body Number: 0038  
LRQA Verification Limited, 1 Trinity Park, Bickenhill Lane,  
Birmingham. B37 7ES

**Authorised Representative** Steven Rohan

Parker Hannifin Manufacturing Limited GSFE

## Declaration

This declaration of conformity issued under the sole responsibility of the manufacturer and the essential safety requirements have been demonstrated and fulfilled in respect of the pressure equipment

**Signature:**



**Date:** 28 March 2022

**Declaration Number:**

00320 / 28.3.22

# EU Declaration of Conformity

EN

Parker Hannifin Manufacturing Limited GSFE  
Dukesway, Team Valley Trading Estate, Gateshead, Tyne & Wear, NE11 0PZ, UK  
Compressed Air Dryer

BASHL050, BASHL055, BASHL060, BASHL065, BASHL070, BASHL075, BASHL080, BASHL085

<b>Directives</b>	PED	2014/68/EU
	LVD	2014/35/EU
	EMC	2014/30/EU

<b>Standards used</b>	PED	Generally in accordance with ASME VIII Div 1 : 2021
	LVD	EN 61010-1 : 2010
	EMC	EN 61326-1 : 2013

**PED Assessment Route:** Module B + D

**PED Certificate Number** 50351

**Notified body for PED:** Notified Body Number: 0525  
Lloyd's Register Deutschland GmbH  
Überseeallee 10,  
D-20457 Hamburg, Deutschland

**Authorised Representative** Steven Rohan

Parker Hannifin Manufacturing Limited GSFE

## Declaration

This declaration of conformity issued under the sole responsibility of the manufacturer and the essential safety requirements have been demonstrated and fulfilled as set out in Annex 1

**Signature:**



**Date:** 28 March 2022

**Declaration Number:**  
00320 / 28.3.22

# PARKER WORLDWIDE

---

**AE – UAE, Dubai**

Tel: +971 4 8127100  
parker.me@parker.com

**AR – ARGENTINA, Buenos Aires**

Tel: +54 3327 44 4129

**AT – AUSTRIA, Wiener Neustadt**

Tel: +43 (0)2622 23501-0  
parker.austria@parker.com

**AT – EASTERN EUROPE,**

Wiener Neustadt  
Tel: +43 (0)2622 23501 900  
parker.easteurope@parker.com

**AU – AUSTRALIA, Castle Hill**

Tel: +61 (0)2-9634 7777

**AZ – AZERBAIJAN, Baku**

Tel: +994 50 2233 458  
parker.azerbaijan@parker.com

**BE/LU – BELGIUM, Nivelles**

Tel: +32 (0)67 280 900  
parker.belgium@parker.com

**BR – BRAZIL, Cachoeirinha RS**

Tel: +55 51 3470 9144

**BY – BELARUS, MINSK**

Tel: +375 17 209 9399  
parker.belarus@parker.com

**CA – CANADA, Milton, Ontario**

Tel: +1 905 693 3000

**CH – SWITZERLAND, Etoy**

Tel: +41 (0)21 821 87 00  
parker.switzerland@parker.com

**CL – CHILE, Santiago**

Tel: +56 2 623 1216

**CN – CHINA, Shanghai**

Tel: +86 21 2899 5000

**CZ – CZECH REPUBLIC, Klecany**

Tel: +420 284 083 111  
parker.czechrepublic@parker.com

**DE – GERMANY, Kaarst**

Tel: +49 (0)2131 4016 0  
parker.germany@parker.com

**DK – DENMARK, Ballerup**

Tel: +45 43 56 04 00  
parker.denmark@parker.com

**ES – SPAIN, Madrid**

Tel: +34 902 330 001  
parker.spain@parker.com

**FI – FINLAND, Vantaa**

Tel: +358 (0)20 753 2500  
parker.fi nland@parker.com

**FR – FRANCE, Contamine s/Arve**

Tel: +33 (0)4 50 25 80 25  
parker.france@parker.com

**GR – GREECE, Athens**

Tel: +30 210 933 6450  
parker.greece@parker.com

**HK – Hong Kong**

Tel: +852 2428 8008

**HU – HUNGARY, Budapest**

Tel: +36 1 220 4155  
parker.hungary@parker.com

**IE – IRELAND, Dublin**

Tel: +353 (0)1 466 6370  
parker.ireland@parker.com

**IN – INDIA, Mumbai**

Tel: +91 22 6513 7081-85

**IT – ITALY, Corsico (MI)**

Tel: +39 02 45 19 21  
parker.italy@parker.com

**JP – JAPAN, Tokyo**

Tel: +81 (0)3 6408 3901

**KR – SOUTH KOREA, Seoul**

Tel: +82 2 559 0400

**KZ – KAZAKHSTAN, Almaty**

Tel: +7 7272 505 800  
parker.easteurope@parker.com

**LV – LATVIA, Riga**

Tel: +371 6 745 2601  
parker.latvia@parker.com

**MX – MEXICO, Apodaca**

Tel: +52 81 8156 6000

**MY – MALAYSIA, Shah Alam**

Tel: +60 3 7849 0800

**NL – The Netherlands, Oldenzaal**

Tel: +31 (0)541 585 000  
parker.nl@parker.com

**NO – NORWAY, Asker**

Tel: +47 66 75 34 00  
parker.norway@parker.com

**NZ – NEW ZEALAND, Mt Wellington**

Tel: +64 9 574 1744

**PL – POLAND, Warsaw**

Tel: +48 (0)22 573 24 00  
parker.poland@parker.com

**PT – PORTUGAL, Leca da Palmeira**

Tel: +351 22 999 7360  
parker.portugal@parker.com

**RO – ROMANIA, Bucharest**

Tel: +40 21 252 1382  
parker.romania@parker.com

**SE – SWEDEN, Spånga**

Tel: +46 (0)8 59 79 50 00  
parker.sweden@parker.com

**SG – Singapore**

Tel: +65 6887 6300

**SK – SLOVAKIA, Banská Bystrica**

Tel: +421 484 162 252  
parker.slovakia@parker.com

**SL – SLOVENIA, Novo Mesto**

Tel: +386 7 337 6650  
parker.slovenia@parker.com

**TH – THAILAND, Bangkok**

Tel: +662 717 8140

**TR – TURKEY, Istanbul**

Tel: +90 216 4997081  
parker.turkey@parker.com

**TW – TAIWAN, Taipei**

Tel: +886 2 2298 8987

**UA – UKRAINE, Kiev**

Tel: +380 44 494 2731  
parker.ukraine@parker.com

**UK – UNITED KINGDOM,**

Warwick  
Tel: +44 (0)1926 317 878  
parker.uk@parker.com

**US – USA, Cleveland**

Tel: +1 216 896 3000

**VE – VENEZUELA, Caracas**

Tel: +58 212 238 5422

**ZA – SOUTH AFRICA,**

Kempton Park  
Tel: +27 (0)11 961 0700  
parker.southafrica@parker.com

**European Product  
Information Centre**

Free phone: 00 800 27 27 5374

(from AT, BE, CH, CZ, DE, EE, ES, FI, FR, IE, IL, IS, IT, LU, MT, NL, NO, PT, SE, SK, UK)

## **PARKER HANNIFIN MANUFACTURING LIMITED**

Gas Separation and Filtration Division EMEA  
Dukesway, Team Valley Trading Est  
Gateshead, Tyne and Wear  
England NE11 0PZ

Tel: +44 (0) 191 402 9000

Fax: +44 (0) 191 482 6296

[www.parker.com/gsfe](http://www.parker.com/gsfe)

