

# VALIDATION GUIDE

## PROPOR LR

Pharmaceutical Grade

Cartridge & Capsule filters



# Contents

<b>CONTENTS</b>	<b>1</b>
<b>1. INTRODUCTION</b>	<b>3</b>
<b>2. QUALITY ASSURANCE</b>	<b>4</b>
2.1. QUALITY AND ENVIRONMENTAL MANAGEMENT SYSTEMS	4
2.2. MANUFACTURING FACILITIES	4
2.3. MATERIAL CONFORMITY	4
2.4. PRODUCT AND LOT RELEASE CRITERIA	4
2.5. PRODUCT TRACEABILITY	5
2.6. PRODUCT SHELF LIFE	5
<b>3. PRODUCT DESCRIPTION</b>	<b>6</b>
3.1. MATERIALS OF CONSTRUCTION	6
3.2. PRODUCT CODING	7
3.3. CARTRIDGE ENDCAP CONFIGURATIONS	9
3.4. CAPSULE DIMENSIONS	10
<b>4. PRODUCT SPECIFICATIONS</b>	<b>12</b>
4.1. CARTRIDGE OPERATING DIFFERENTIAL PRESSURES AND TEMPERATURES	12
4.2. CAPSULE OPERATING PRESSURES AND TEMPERATURES	13
4.3. FLOW RATES	15
4.4. EFFECTIVE FILTRATION AREA (EFA)	16
4.5. HOLD UP VOLUME	16
4.6. AUTOCLAVE LIFE	17
4.7. CARTRIDGE STEAM LIFE	19
4.8. RETENTION	20
4.9. DIFFUSIONAL FLOW CORRELATION DATA	21
4.10. INTEGRITY TESTING DATA	22
4.11. GAMMA STERILIZATION (CAPSULES)	23
4.11.1. VALIDATION OF GAMMA STERILIZATION PROCESS	23
4.12. CHEMICAL COMPATIBILITY	24
<b>5. CARTRIDGE AND CAPSULE CLEANLINESS</b>	<b>27</b>
5.1. GRAVIMETRIC NON VOLATILE EXTRACTABLES IN WATER	27
5.2. BUFFERING CAPACITY	28
5.3. BACTERIAL ENDOTOXINS	29
5.4. PARTICLE AND FIBRE SHEDDING	30
5.5. OXIDIZABLE SUBSTANCES	32
5.6. TOTAL ORGANIC CARBON AND IONIC SUBSTANCES	33
5.7. DETERMINATION OF EXTRACTED CHEMICAL COMPOUNDS	34
<b>6. TESTS FOR BIOCOMPATIBILITY</b>	<b>36</b>
<b>7. CERTIFICATE OF CONFORMANCE</b>	<b>37</b>

# 1. Introduction

Sterilization grade filters that come into contact with pharmaceutical products, such as injectable or infusion liquids, must conform to strictly defined quality standards.

By using filter technology that conforms to the standards laid down by the various certifying bodies, the quality of the final product can be assured. Contamination can also be prevented from entering the final product by its comprehensive removal at each stage of the primary and secondary process.

When sterilizing grade filters are used in the manufacture of products, the interactions between product, filter and process must be fully investigated and validated.

Guidelines for validation can be sourced from publications issued by the FDA, EMEA, USP, EP, BP, PDA<sup>1</sup>, etc. This validation document has been produced with these guidelines in mind to enable the end user to incorporate this information within their own validation documentation or standard operating instructions for the process.

## NOTE

**If printed with the banner **UNCONTROLLED COPY**, this validation document has not been registered. If you wish to receive amendments and updates automatically, then please contact the department below or fax this page with your name and address and we will send you a registered copy:**

The Quality Assurance Department  
 Parker Hannifin Manufacturing Ltd  
 Durham Road, Birtley, Co. Durham, UK, DH3 2SF  
 Tel: +44 (0)191 410 5121  
 Fax: +44 (0)191 410 5312  
 E-mail: dhprocess@parker.com

### Registered Holder Information

Name: .....

Company: .....

Department: .....

Address: .....

.....

.....

.....

Registered No. ....

Date Issued: .....

Signed .....

<sup>1</sup> FDA, EMEA, USP, EP, BP, PDA – Food and Drug Administration, European Medicines Evaluation Agency, United States, European and British Pharmacopoeia, Parenteral Drug Association.

## 2. Quality Assurance

Quality is built into all Parker domnick hunter filtration products through a rigorous product design process, careful selection of suppliers and materials, and manufacture within a highly controlled environment using validated production technologies in adherence to cGMP.

### 2.1. Quality and Environmental Management Systems

Parker domnick hunter is certified to current versions of the following quality standards by Lloyds Register Quality Assurance.

- BS EN ISO9001                      Quality Management Systems
- BS EN ISO14001                  Environmental Management Standard
- BS EN ISO13485                  Medical Devices

Copies of the original certificates are available upon request.

### 2.2. Manufacturing Facilities

Parker domnick hunter continues to invest substantially in installation of the latest clean room and manufacturing technology. All manufacturing systems are validated using statistical methodologies (process, product and software) and constantly monitored using statistical process control charts. All personnel within the manufacturing operations are fully trained in cGMP and against competency frameworks to ensure their suitability to operate within specific manufacturing areas.

### 2.3. Material Conformity

Parker domnick hunter works closely with suppliers to ensure materials supplied are of a consistently high quality and also to develop new materials as part of our ongoing product development activity. In addition to supplier certificates of conformity and analysis, incoming raw materials, including moulded parts, membranes and supports, and elastomeric seals, are subject to an appropriate level of incoming inspection. This includes bacterial challenge on each lot of membrane used in the manufacture of sterilising grade filter cartridges and capsules.

### 2.4. Product and Lot Release Criteria

Prior to shipment all Parker domnick hunter cartridges and capsules undergo final product quality control. 100% of testable products undergo a non-destructive integrity test (diffusional flow). This includes a high volume flush with water that meets or exceeds the current EP and USP standards for purified water. Products are dried using HEPA filtered air and sealed in a protective polyethylene bag within the controlled manufacturing environment prior to final pack and despatch.

In addition a sample is taken from each production lot and tested to demonstrate conformity to validated claims.

## 2.5. Product Traceability

The product code and type, lot number and unique capsule serial number are printed on all products. Additionally, the lot number is identified on the protective bag label and the box label within which the cartridge / capsule is packed. The serial number provides complete traceability back to pleated materials used in the manufacture of each capsule and the manufacturing processes through the module routing sheet.

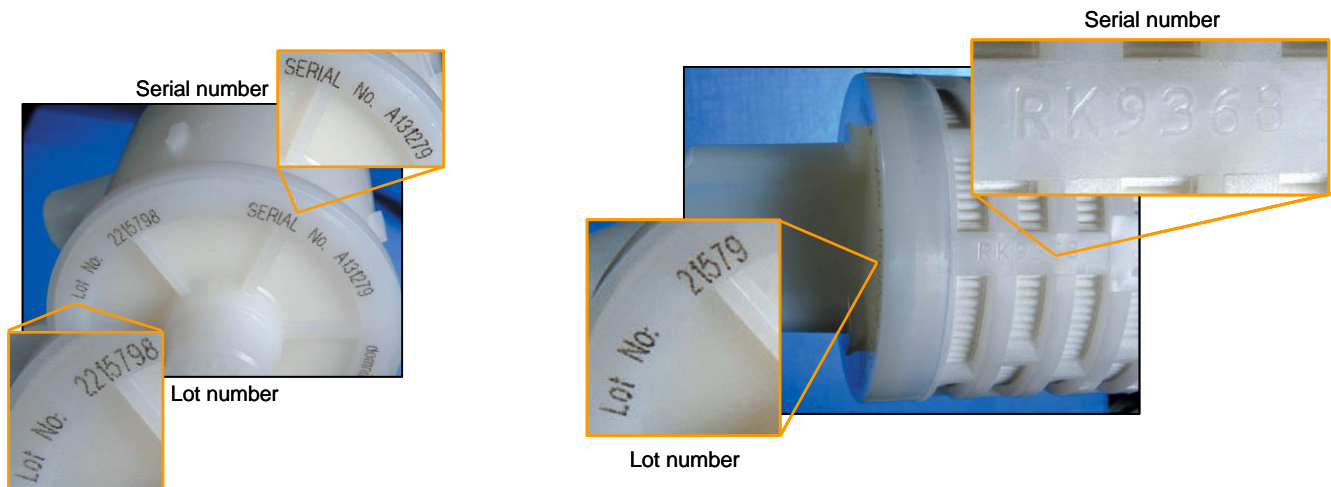

## 2.6. Product Shelf Life

The shelf life for PROPOR LR cartridges and capsules is 3 years (2 years for irradiated product).

### 3. Product Description

All products within the PROPOR LR range have been designed for use in bioprocessing and pharmaceutical applications. All jointed surfaces are assembled by the use of heat sealing technology. No resins or binders are used in the manufacture of the filter and no surfactants are added to aid wetting.

#### 3.1. Materials of construction

All materials meet the FDA requirements as defined in Title 21 Code of Federal Regulations and the BioSafety Tests as defined in the current USP including the Class VI Plastics Testing.

■ Filtration Membrane	Polyethersulphone
■ Upstream Support	Polyester
■ Downstream Support	Polyester
■ Inner Core	Polypropylene
■ Sleeve	Polypropylene
■ Endcaps (cartridge)	Nylon
■ Capsule body (DEMICAP)	Nylon
■ Capsule body (MURUS)	Polypropylene
■ Capsule vent seals	Silicone
■ Cartridge o-rings ( standard)	Silicone
■ Filling bell	Polycarbonate

### 3.2. Product Coding

Product code structures indicate the cartridge / capsule sizes, micron ratings, endcap configurations and o-rings that are available within the product range.

#### Cartridges

Example ZCLR2-010C-PS

500 mm (20") 0.1 micron PROPOR LR filter cartridge, pharmaceutical grade with 'C' style endcap and silicone o-rings.

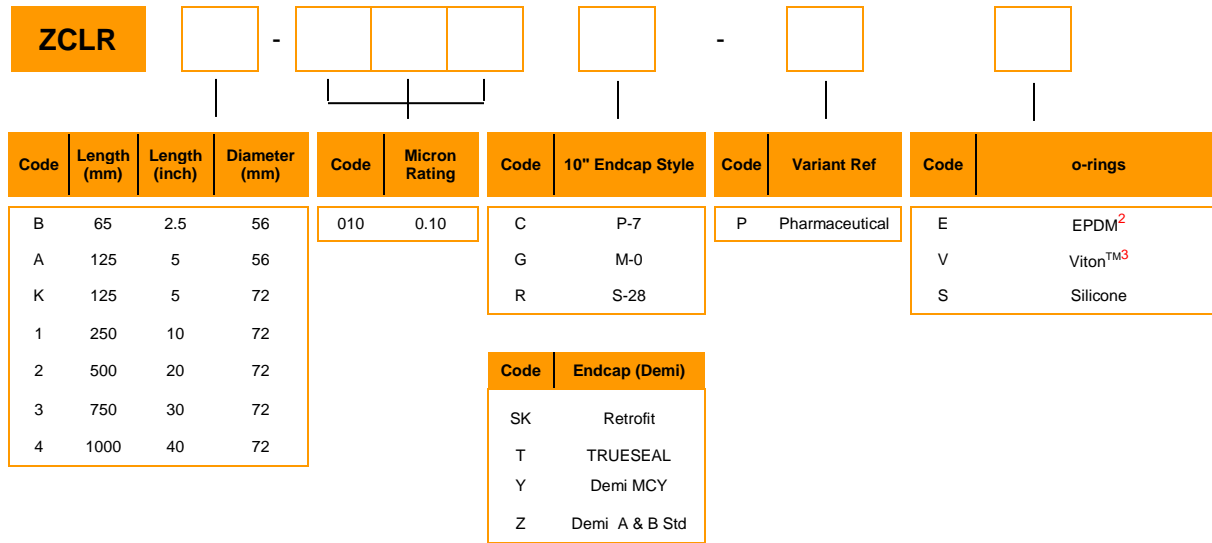

#### Small-Scale DEMICAP Capsules

Example ZELRB-010TT-PN3

B size 0.1 micron PROPOR LR DEMICAP capsule, pharmaceutical grade with tri-clamp connections supplied non-sterile in packs of 3.

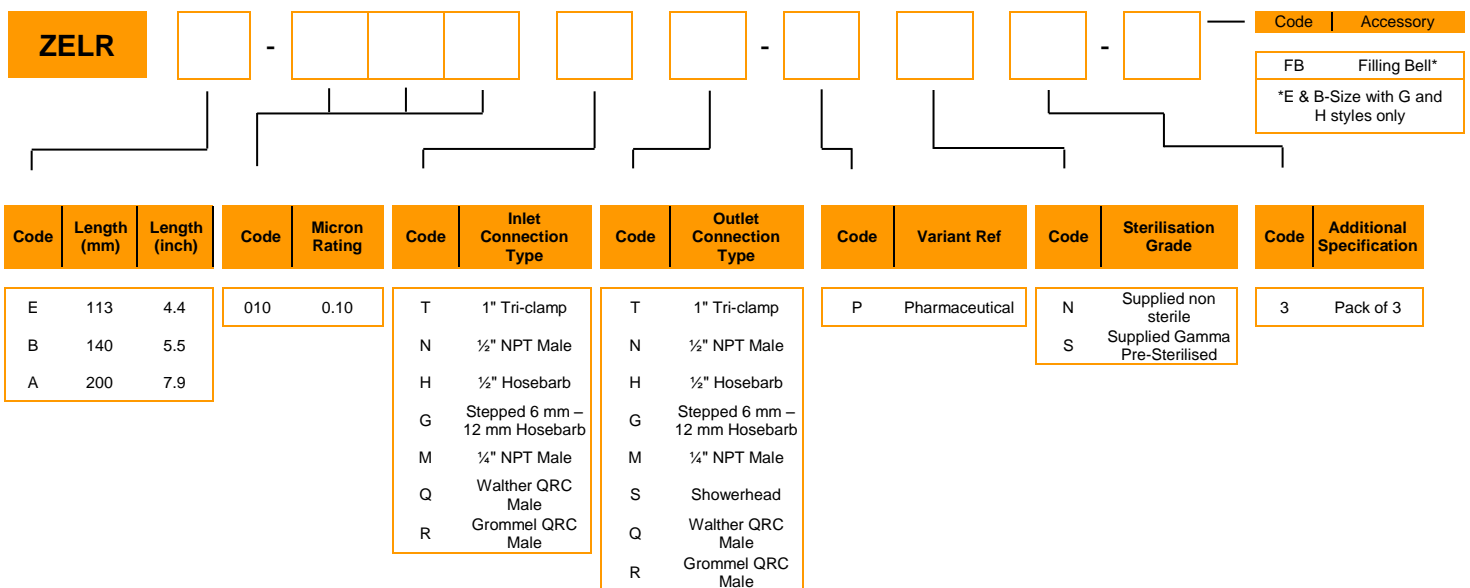

<sup>2</sup> EPDM – Ethylene Propylene Diene Monomer Rubber  
<sup>3</sup> Viton™ is a registered trademark of DuPont Dow Corporation

## Large Scale MURUS capsules

Example ZLLR1-010TT-PN-L-S

10" 0.1 micron PROPOR LR MURUS capsule with tri-clamp connections, pharmaceutical grade, supplied non-sterile with inline design and silicone o-rings.

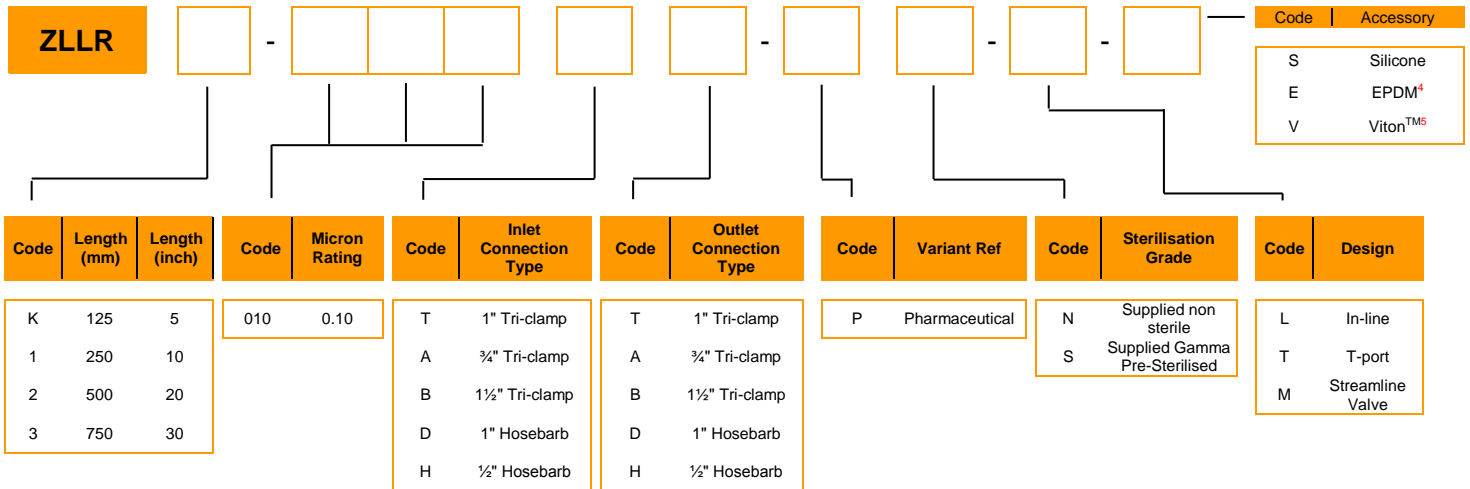

<sup>4</sup> EPDM – Ethylene Propylene Diene Momomer Rubber.

<sup>5</sup> Viton is a registered trademark of DuPont Dow Corporation.

### 3.3. Cartridge Endcap Configurations

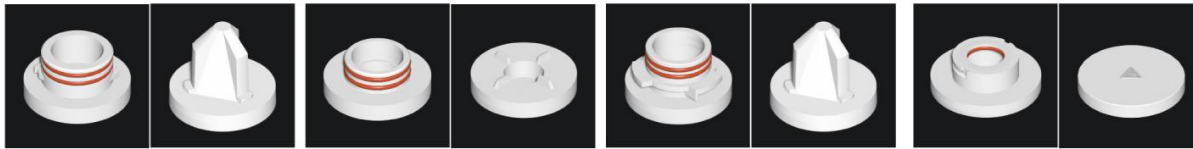

A Style 223 o-rings

G Style 222 o-rings

R Style 222 o-rings

X Style 116 o-rings  
(Demi Only)

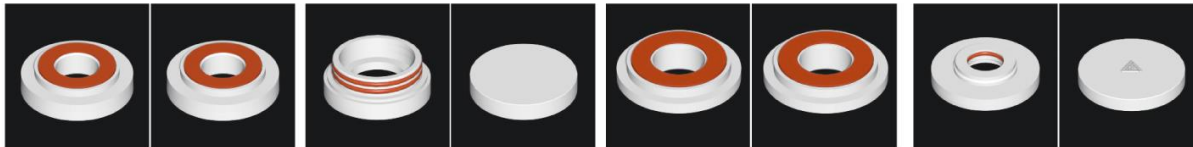

B,L Style Flat Gaskets

H Style 54mm ID  
x 4mm o-rings

S Style Flat Gaskets

Y Style 116 o-rings  
(Internal) (Demi Only)



C Style 226 o-rings

J Style S.O.E.

U Style 222 o-rings

Z Style 116 o-rings  
(Internal) (Demi Only)



D Style 222 o-rings

K Style 214 o-rings  
(Internal)

SK Style  
(Demi Only)



E Style 222 o-rings

M,N Style 214 / 213  
o-rings (Internal)

T Style 126 o-rings  
(Demi Only)

X Style 1/2" NPTM  
Thread & Gasket

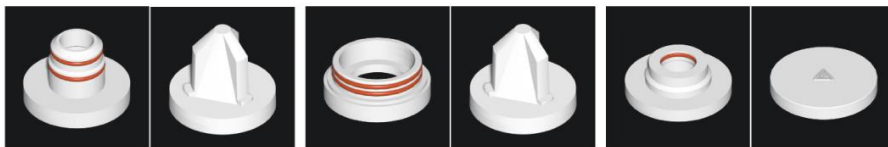

F Style 216 / 218  
o-rings

P Style 227 o-rings

W Style 111 o-rings  
(Demi Only)

V Style BSPP  
Thread & Gasket

Autoclave Vent Filter Endcaps

### 3.4. Capsule Dimensions

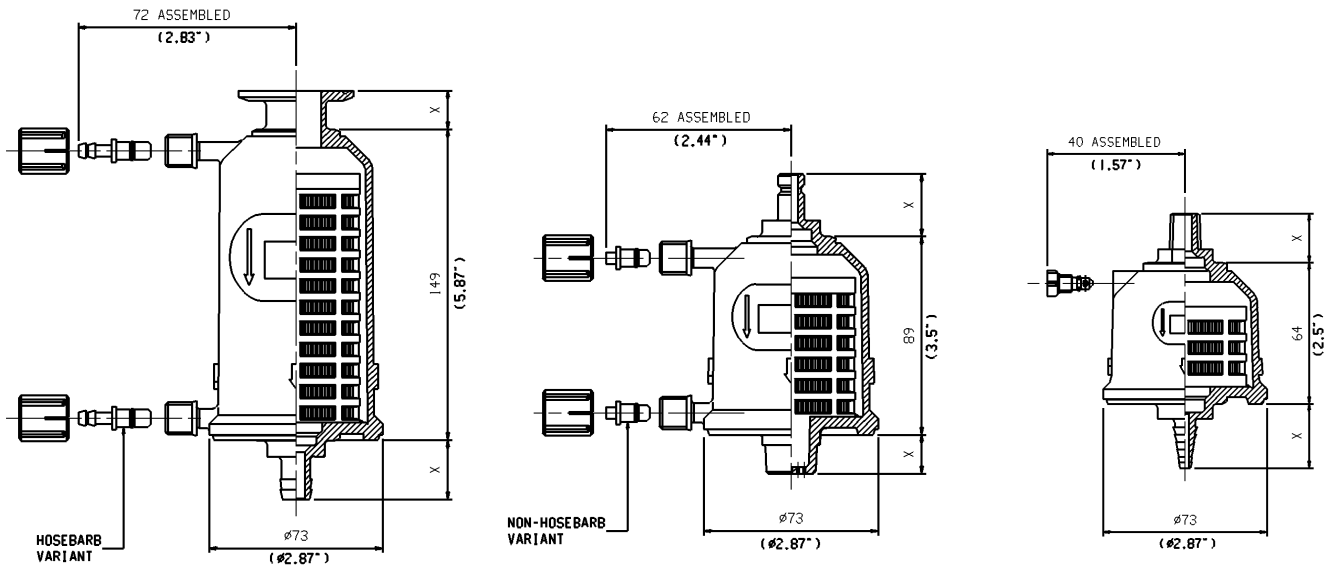

#### Dimensions

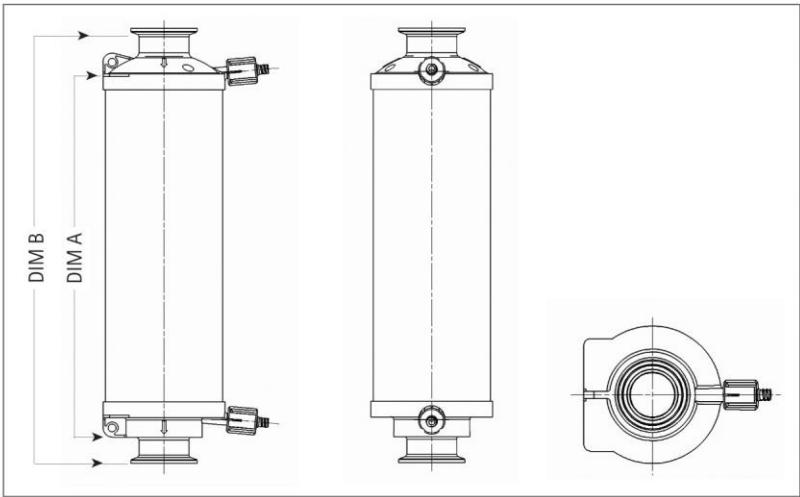

Cartidge Type		Dimension A	Dimension B
10"	250mm	10.30" 262mm	13.07" 332mm
20"	500mm	20.04" 509mm	22.79" 579mm
30"	750mm	29.80" 757mm	32.56" 827mm

Dimensions shown are typical lengths for 1 1/2" Tri-Clamp. Further dimensions available from domnick hunter.

### DEMICAP Inlet / Outlet Connection Styles



1" Tri-Clamp



Stepped Hosebarb



1/4" NPTM Thread



1/2" Hosebarb



1/2" NPTM Thread

### MURUS Inlet/Outlet Connection Styles



1 1/2" Tri-Clamp



1" Hosebarb



1" Tri-Clamp



1" Tri-Clamp T-Port



3/4" Tri-Clamp

## 4. Product Specifications

### 4.1. Cartridge Operating Differential Pressures and Temperatures

The maximum operating temperatures and differential pressures were qualified by running water at temperature through representative products of the PROPOR 10 inch cartridge range for 30 minutes.

Serial Number	Batch Number	Differential Pressure (barg)	Temperature (°C)	Differential Flow (ml / min)
20703CA	2F8076	4.1	40	5.7
20718CA	2F8075	4.1	40	4.7
20685CA	2F8074	4.0	40	5.1
20701CA	2F8076	3.0	60	4.1
20713CA	2F8075	3.0	60	6.3
20690CA	2F8074	3.0	60	4.0
20703CA	2F8076	2.0	82	7.3
20718CA	2F8075	2.0	80	5.2
20685CA	2F8074	2.0	80	4.2

Note: The maximum allowable diffusional flow is 16 ml / min.

### Conclusion

The recommended maximum differential operating pressures at various temperatures are shown below:

Temperature		Differential Pressure	
°C	°F	bar	psi
20	68	5.00	72.5
40	104	4.00	58.0
60	140	3.00	43.5
80	176	2.00	29.0
90	194	1.70	24.6

## 4.2. Capsule Operating Pressures and Temperatures

Testing to verify the maximum operating temperatures and pressures was conducted post autoclaving and post irradiation to simulate worst-case conditions.

### DEMICAP

#### Post Autoclave (11 Porous load cycles @ 130°C)

Serial Number	Batch Number	Capsule Surface Temperature (°C)	Burst Pressure (barg)
DC272048	3485129	44.3	9.65
DC272053	3485129	45.0	8.56
DC273519	3485129	44.4	8.34
DC289414	3506050	44.4	9.97
DC289415	3506050	45.3	9.14
DC289416	3506050	44.7	9.66
DC289417	3506050	45.0	10.08
DC289418	3506050	44.8	8.51
DC289419	3506050	45.7	8.90

#### Post Irradiation (minimum dose of 45.6 kGys)

Serial Number	Batch Number	Capsule Surface Temperature (°C)	Burst Pressure (barg)
DC294108	3500959	45.0	10.08
DC294110	3500959	45.0	10.67
DC294113	3500959	44.9	9.38
DC294142	3504739	45.0	9.29
DC294143	3504739	44.6	8.34
DC294146	3504739	42.4	8.57
DC289422	3506051	44.2	7.97
DC289423	3506051	44.3	9.28
DC289424	3506051	44.2	8.49

### Conclusion

The recommended maximum operating temperature and pressure for the PROPOR LR DEMICAP range of capsules has been set at 5.0 barg @ 40°C.

## MURUS Large-Scale Capsule

The maximum operating temperatures and pressures for the MURUS range were evaluated using the PROPOR SG cartridge variant. This is applicable for the complete range as it is the capsule housing integrity and the seals which are being tested and these are common across the PROPOR range. The results below are a sample from the those manufactured during validation.

### Post Autoclave for 10" Capsules (5 Porous load cycles @ 130°C)

Serial Number	Burst Pressure barg @ 25°C
9134MU001	22.41
9134MU002	23.36
9134MU003	17.80
9134MU004	20.90
9134MU005	20.92
9134MU006	23.63

### Post Irradiation for 10" Capsules (minimum dose of 45.6 kGys)

Serial Number	Burst Pressure barg @ 25°C
9233MU006	18.67
9233MU008	18.24
9233MU010	17.20
9233MU012	19.11
9233MU014	20.52
9233MU016	20.58

### Elevated Temperature

Serial Number	Capsule Surface Temperature (°C)	Burst Pressure barg
9171MU001	52.9	13.37
9171MU003	54.3	16.71
9171MU005	52.6	14.30
9171MU007	53.0	14.59
9171MU009	52.3	13.12
9171MU012	54.2	14.25

### Conclusion

From the data above the recommended maximum operating temperatures and pressures for the PROPOR LR MURUS range of capsules has been set at 5.5 barg @ 25°C and 2.8 barg @ 60°C.

### 4.3. Flow Rates

Cartridge flow rates were determined for filters from three separate lots. The flow rates for the MURUS capsule range are the same as those for the equivalent size cartridge

#### Water Flow Characteristics for 10 inch Cartridges & Capsules

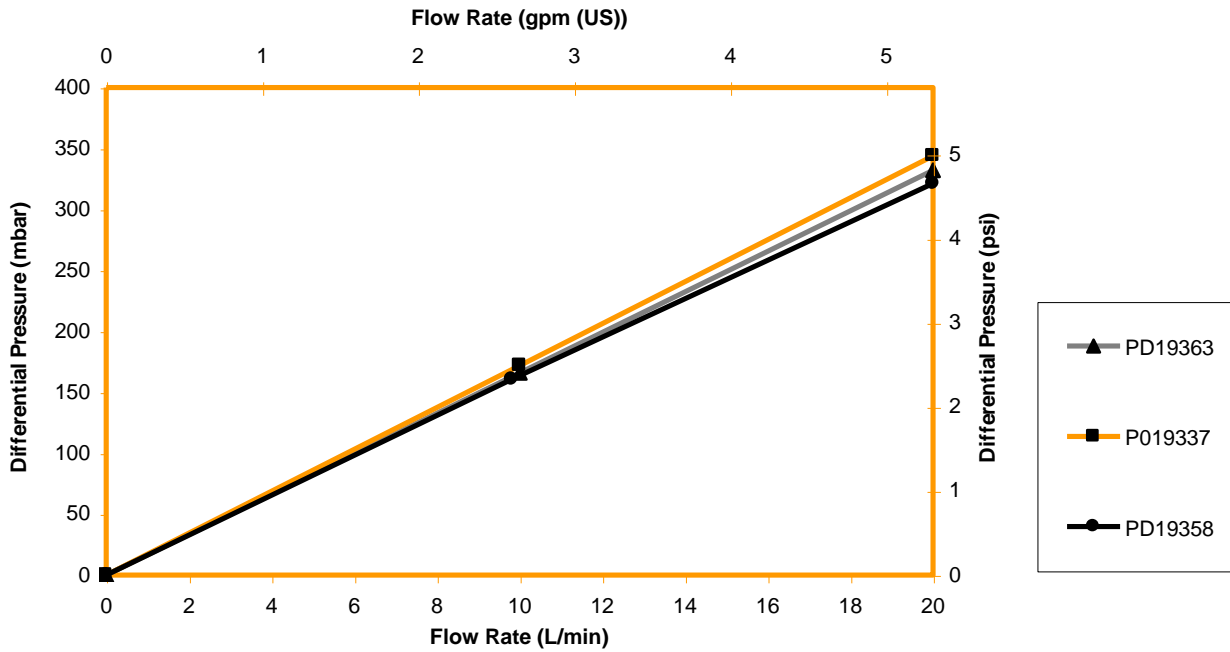

#### Average Water Flow Rates for Small Scale Cartridges & Capsules

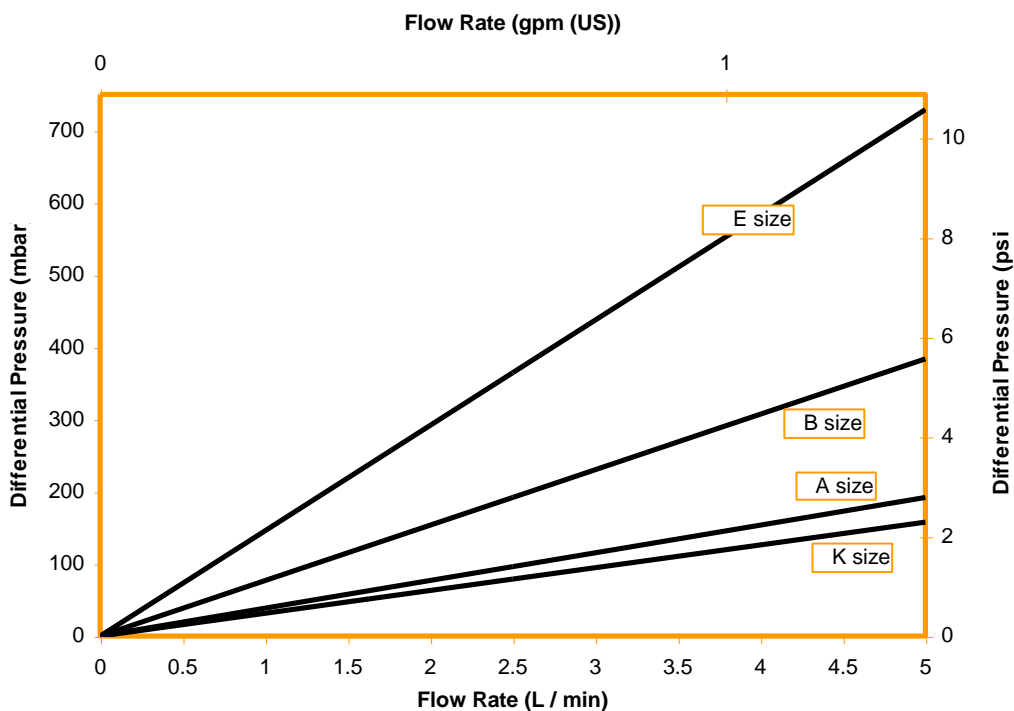

**4.4. Effective Filtration Area (EFA)**

Product Size	Surface Area (m <sup>2</sup> )	Surface Area (ft <sup>2</sup> )
4	2.20	23.67
3	1.65	17.75
2	1.10	11.84
1	0.55	5.92
K	0.26	2.79
A	0.20	2.15
B	0.10	1.07
E	0.05	0.53

**4.5. Hold Up Volume**

<b>Pharmaceutical Capsule Product Hold Up Volumes (ml)</b>						
Product	1 barg Air purge			2 barg air purge		
	A size	B size)	E size	A size)	B size	E size
PROPOR LR	61.4	31.4	19.4	40.5	21.6	15.2

## 4.6. Autoclave Life

The autoclave life of capsules was determined using a porous load cycle.

The resistance to autoclaving was determined by evaluating the integrity of nine 'B' size capsules pre and post autoclaving.

Serial Number	Integrity Test Values Post Autoclave @ 130°C		
	0 Cycles	11 Cycles	
	Diffusional Flow (ml / min)	Diffusional Flow (ml / min)	Bubble Point (mbar)
DC453915	2.9	4.4	4086
DC453916	3.5	4.2	3834
DC453919	3.9	4.3	4084
DC453920	3.4	4.2	3736
DC453922	2.6	3.9	4136
DC453923	3.3	4.5	3836
DC453925	3.0	4.2	3886
DC453926	3.3	4.2	3984
DC453928	2.9	3.9	3983

NOTE: Maximum allowable diffusional flow for an B size PROPOR LR is 4.9 ml / min  
Minimum bubble point in 60 /40 IPA / Water for a PROPOR LR is 2.10 bar.

### Conclusion

The PROPOR LR range of filter capsules can be autoclaved up to 10 cycles at 130°C (266°F), which includes a 10% safety factor.

## MURUS Large-Scale Capsules

The autoclave life of capsules was determined using a porous load cycle.

The resistance to autoclaving was determined by integrity testing nine 10" size MURUS PROPOR SG capsules pre and post autoclaving. Testing of the PROPOR SG is applicable for the complete range as it is the capsule housing integrity and the seals that are being tested and these are common across the PROPOR range. The results below are a sample from those manufactured during validation

Serial Number	Integrity Test Values Post Autoclave @ 130°C	
	0 Cycles	5 Cycles
	Diffusional Flow (ml / min)	Diffusional Flow (ml / min)
1934MU001	5.1	8.5
1934MU002	6.6	9.7
1934MU003	6.7	13.1
1934MU004	3.6	9.2
1934MU005	4.6	8.8
1934MU006	8.3	13.0
1934MU007	7.2	14.5
1934MU008	9.2	11.2
1934MU009	4.1	9.9

NOTE: Maximum allowable diffusional flow for an 10" MURUS PROPOR SG is 16.0 ml / min

### Conclusion

The PROPOR LR range of filter capsules can be autoclaved up to 5 cycles at 130°C (266°F).

### 4.7. Cartridge Steam Life

The steam life of cartridges was determined using the Steam in Place (SIP) cycle shown below, which replicates extreme conditions. This includes a combination of steaming for 30 minutes at temperature followed by ambient water flow during the cooling phase of each cycle.

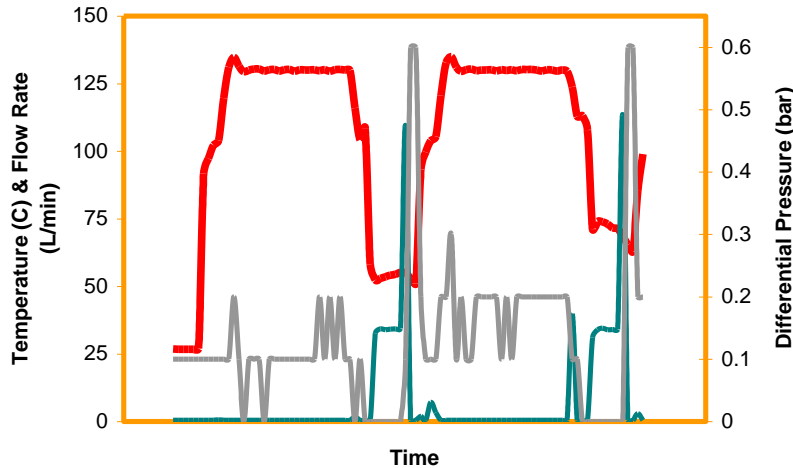

— Temperature    — Water flow    — Differential pressure

The resistance to steam sterilisation was determined by evaluating three production batches consisting of 9 off 10 inch cartridges per batch. A representative sample is shown below.

Batch	Serial No	Integrity Test Values post SIP @ 130°C					
		0 cycles		11 cycles		33 cycles	
		Diff flow (ml/min)	B.pt (mbar)	Diff flow (ml/min)	B.pt (mbar)	Diff flow (ml/min)	B.pt (mbar)
1	09304DB	20.7	2586	17.3	2683	19.5	2684
	09305DB	22.2	2631	17.0	2724	18.2	2719
	09332DB	21.7	2631	16.9	2686	18.7	2716
2	09300DB	20.8	2626	18.5	2686	18.9	2720
	09302DB	20.6	2632	17.7	2720	19.9	2728
	09308DB	21.6	2620	17.9	2686	16.7	2685
3	09295DB	23.8	2635	19.6	2716	19.0	2713
	09297DB	22.6	2669	18.1	2734	18.2	2733
	09299DB	21.4	2630	17.0	2686	18.9	2711

NOTE: Maximum allowable diffusional flow for an B size PROPOR LR is 27.0 ml / min  
 Minimum bubble point in 60 /40 IPA / Water for a PROPOR LR 2.10 bar.

### Conclusion

The PROPOR LR range of filter cartridges can be steam sterilised up to 30 cycles at 130°C (266°F), which includes a 10% safety factor.

## 4.8. Retention

The correlation between bacterial challenge and a non-destructive integrity test has been demonstrated using the procedure documented in the current revision of ASTM F838 'Standard Test Method for Determining Bacterial Retention of Membrane Filters Utilized for Liquid Filtration'<sup>6</sup>. This procedure is recognised for establishing the retention performance of a 0.2 µm sterilizing grade filter to *Brevudimonas diminuta* (ATC19146). There is no recognised standard for a 0.1 µm rated filter so the performance of the PROPOR LR has been evaluated in two ways:

1. Correlation between the retention of *Ralstonia pickettii* (NCIMB 13142) and a diffusional flow integrity test. This organism was used as it is a frequent known contaminant in purified water systems and has been shown to penetrate standard 0.2 µm sterilising grade filters.
2. A bacterial challenge with *Brevudimonas diminuta* (ATC19146) to prove the PROPOR LR can be classified as a sterilizing grade filter

### Liquid Bacterial Challenge Schematic

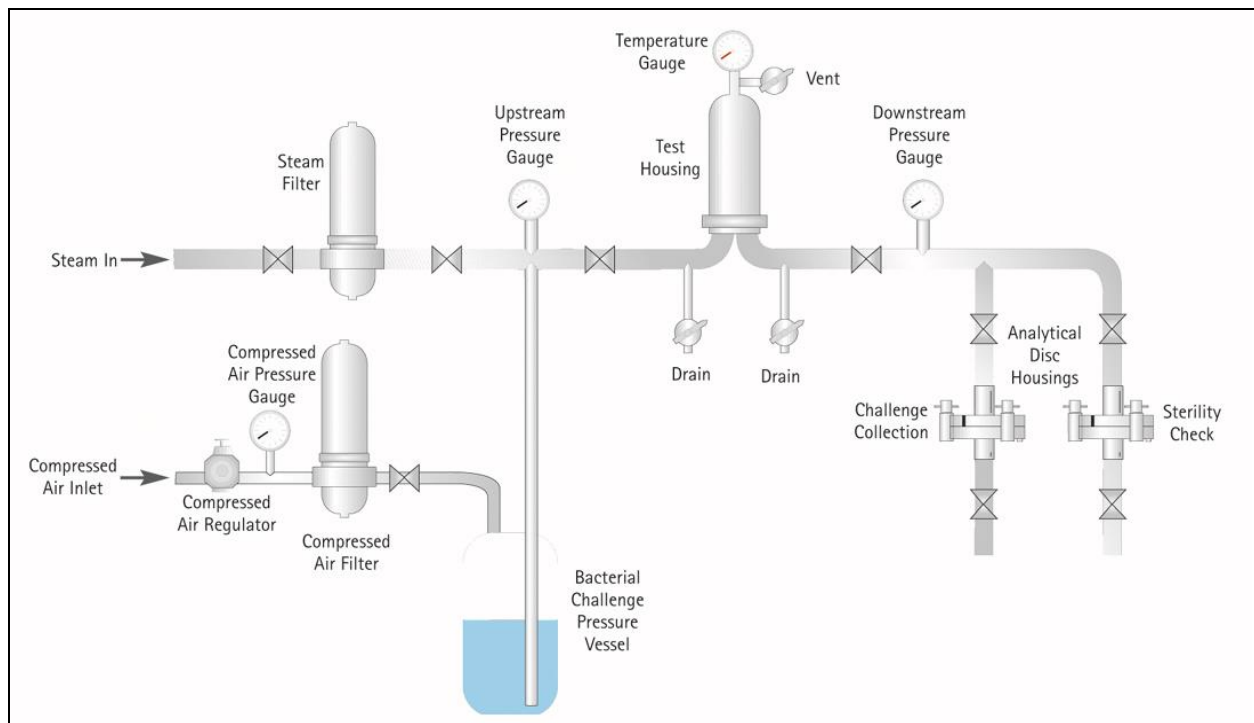

Under these test conditions, the test filter is challenged with a minimum of  $10^7$  viable *Ralstonia pickettii* (NCIMB 13142) per square centimetre of effective filtration area. Any organisms that pass through the test filter are collected and cultured on the surface of analytical discs. In this way colonies may be counted and bacterial species identified. The filter retention is quantified by expressing the filter's efficiency to remove the challenge organism from the challenge suspension as a Log Reduction Value (LRV).

$$\text{LRV} = \text{Log}_{10} \left( \frac{\text{Number of organisms in the challenge}}{\text{Number of organisms in the filtrate}} \right)$$

<sup>6</sup> Previous reference to the guidance document *Microbial Evaluation of Filters for Sterilising Liquids*, HIMA Document No. 3 Vol. 4, April 1982, referred to in USP<1211> *Sterilisation by Filtration* has been superseded by the equivalent ASTM F838.

## 4.9. Diffusional Flow Correlation Data

### *Ralstonia pickettii* (NCIMB 13142)

The correlation between diffusional flow and bacterial challenge for PROPOR LR cartridges is shown in the table below. This data shows that a 250mm (10") PROPOR LR 0.10 µm filter exhibiting a diffusional flow of <31.4 ml/min when completely wetted with water, at a test pressure of 4.20 barg (61.0 psig) at 20°C (68°F) will produce a sterile filtrate.

Filter type: ZCLR1 -010C-P PROPOR LR 0.10 µm 10" cartridge

Challenge organism: *Ralstonia pickettii* (NCIMB 13142)

Serial No.	Diffusional Flow (Air in Water) @ 4.20 barg (61.0 psig) ml/min	Total Challenge Level Cfu (x10 <sup>11</sup> )	Organisms Passed cfu	LRV <sup>7</sup>
P019343	6.6	2.21	0	11.34
TC2212	20.6	1.23	0	11.09
TC2214	20.6	174	0	13.24
P015126	22.1	3.87	0	11.59
P015117	27.2	2.39	0	11.38
P019355	27.6	1.74	0	11.24
P019375	27.9	0.90	0	10.96
P019353	28.1	0.98	0	10.99
TC2218	28.3	2.51	0	11.40
P019350	29.1	3.25	0	11.51
P019373	29.2	0.89	0	10.95
P015128	31.0	1.02	0	11.01
SK2200	31.4	1.97	0	11.30
P019374	32.1	1.05	377	8.44
P014406	32.9	161	1601	10.00
P019368	36.0	127	2012	9.80
P019359	36.4	1.14	0	11.06
P019362	37.8	0.91	0	10.96
P019364	53.9	2.04	0	11.31

NOTE: The maximum allowable diffusional flow for a 10 inch PROPOR LR is 27 ml / min

### Conclusion

A maximum diffusional flow of 27ml/min for a water wetted 10" PROPOR LR filter cartridge provides complete assurance of a sterile effluent incorporating as it does a safety margin in relation to the correlation data above.

<sup>7</sup> Where organisms passed = 0, LRV is stated as *greater than*.

***Brevundimonas diminuta* (ATCC 19146)**

To conform to the standard industry requirements for a sterilizing grade filter a sample of the PROPOR LR filters has also been challenged with *Brevundimonas diminuta* to ensure full retention.

Serial No.	Diffusional Flow (Air in Water) @ 4.20 barg (61.0 psig) ml/min	Total Challenge Level Cfu (x10 <sup>11</sup> )	Organisms Passed cfu	LRV <sup>8</sup>
97476	12.2	4.0	0	11.6
97475	11.4	3.6	0	11.6
97452	18.1	3.7	0	11.6
97470	15.4	3.0	0	11.5
97453	18.1	4.4	0	11.6

Conclusion

All filters provided sterile effluent proving the PROPOR LR is fully retentive and can be classified as a sterilizing grade filter.

**4.10. Integrity Testing Data**

The following integrity test limits have been determined from the 10 inch cartridge correlation data above. Limits for other sizes have been calculated directly from effective filtration area ratios for each variant. These limits are for water wet cartridges using air as the test gas.

Micron Rating	Minimum Bubble point <sup>9</sup> (60/40 IPA /water)		Diffusional Flow Test Pressure		Maxi mum Diffus ional Flow 40"	(ml / min)				K	A	B	E
	bar	psi	bar	psi		30"	20"	10"					
0.1	2.10	30.0	4.20	61.0	108.0	81.0	54.0	27.0	12.6	10.1	4.9	2.1	

<sup>8</sup> Where organisms passed = 0, LRV is stated as *greater than*.

<sup>9</sup> Parker domnick hunter does not recommend the use of bubble point as an integrity test method for cartridges but values are given for use as an indicator of product integrity.

## 4.11. Gamma Sterilization (Capsules)

### 4.11.1. *Validation of gamma sterilization process*

The required sterilisation dose was determined from an analysis of the bioburden from three discrete production batches of DEMICAP products in accordance with VDMAX Method "Substantiation of 25 kGy as a sterilising dose: A rational approach to establishing a verification dose" ref: ISO/EN WD,11137-3.

The average bioburden for the three batches of product tested when compared with reference to AAMI TIR27 indicated a sub process dose for a sterility assurance level of  $10^{-2}$  to be 9.1 kGy. Ten capsules were subsequently irradiated at 9.1 kGy and individually tested for sterility. After the full incubation period zero tests gave a positive result therefore substantiating 25 kGy as a sterilization dose and guaranteeing an SAL of  $10^{-6}$  in accordance with ISO/EN WD, 11137-2.

### Conclusion

The current sterilization dose of 25 to 40 kGy is substantially in excess of the calculated sub process dose providing a high level of assurance of product sterility.

### 4.12. Chemical Compatibility

The following data is indicative of PROPOR LR cartridge & capsule compatibility with a range of chemicals at ambient temperature and 72 hour exposure. However it is recommended that specific process conditions are reviewed with your local Parker domnick hunter representative.

	BIO-X II	HIGH FLOW BIO-X	HIGH FLOW BIO-X VENT AUTOCLAVE	HIGH FLOW PREPOR GFA	HIGH FLOW TETPOR II	HIGH FLOW TETPOR H.T.	HIGH FLOW TETPOR VENTAUTOCLAVE	PROCLEAR PP	PROCLEAR GF	PROCLEAR GP	PROPOR MR	PROPOR SG	PROPOR HC	PROPOR BR	PROPOR LR	TETPOR AIR	TETPOR LIQUID	TETPOR PLUS	EPDM o-ring	VITON o-ring	SILICONE o-ring
Acetic acid 3.5N	C	C	C	C	C	C	C	C	C	C	C	C	C	C	C	C	C	C	C	C	C
Acetic acid 8.75N	C	C	-	C	C	C	C	C	C	C	-	-	-	-	-	C	C	C	LC	LC	NC
Acetic acid conc.17.5N	C	C	-	C	C	C	C	C	C	C	-	-	-	-	-	C	C	C	LC	NC	NC
Acetone	C	C	-	C	C	C	C	C	C	C	NC	NC	NC	NC	NC	C	C	C	NC	NC	NC
Acetonitrile	C	C	-	LC	C	C	C	C	LC	LC	-	-	-	-	-	C	C	C	NC	NC	NC
Acidbrite 4 (Diversey) 3.0% <sub>v/v</sub>	-	-	-	C	-	-	-	C	C	C	-	-	-	-	-	-	-	-	C	C	C
Ammonium Hydroxide 8N	C	C	C	C	C	C	C	C	C	C	LC	LC	LC	LC	LC	C	C	C	C	C	C
Ammonium Oxalate 0.07N	C	C	C	C	C	C	C	C	C	C	-	-	-	-	-	C	C	C	C	C	C
Amyl Acetate	C	C	C	LC	C	C	C	C	LC	LC	LC	LC	LC	LC	LC	C	C	C	NC	NC	LC
Aqueous Ammonia 15.5N	C	C	C	LC	C	LC	C	C	LC	LC	LC	LC	LC	LC	LC	C	C	C	C	C	C
Benzyl Alcohol	C	C	C	NC	C	C	C	NC	NC	NC	-	-	-	-	-	C	C	C	C	C	C
Benzyalkonium Chloride 0.1%	C	C	C	C	C	C	C	C	C	C	-	-	-	-	-	C	C	C	C	C	C
Boric acid,saturated	C	C	C	C	C	C	C	C	C	C	-	-	-	-	-	C	C	C	C	C	C
Butan-1-ol	C	C	C	C	LC	LC	LC	C	C	C	C	C	C	C	C	NC	NC	NC	C	C	C
Butan-2-ol	C	C	C	C	C	C	C	C	C	C	C	C	C	C	C	C	C	C	LC	C	C
Carbon Tetrachloride	C	C	C	NC	C	C	C	NC	NC	NC	-	-	-	-	-	NC	NC	NC	NC	C	NC
Chloroform	C	C	C	NC	C	C	C	NC	NC	NC	NC	NC	NC	NC	NC	NC	NC	NC	NC	LC	NC
Cyclohexane	C	C	C	NC	-	-	-	NC	NC	NC	-	-	-	-	-	LC	LC	LC	NC	NC	NC
1,4 – Dioxane	C	C	C	LC	C	C	C	C	LC	LC	-	-	-	-	-	C	C	C	NC	NC	NC
Diverflow (Diversey) 3% <sub>v/v</sub>	-	-	-	NC	-	-	-	C	NC	NC	C	C	C	C	C	-	-	-	C	C	LC
Diversey 212G 0.6% <sub>v/v</sub>	-	-	-	C	-	-	-	C	C	C	-	-	-	-	-	-	-	-	C	C	C
Divosan Forte 0.5% <sub>v/v</sub>	-	-	-	C	-	-	-	C	C	C	C	C	C	C	C	-	-	-	C	C	C
Divosan XT 1% <sub>v/v</sub>	-	-	-	C	-	-	-	C	C	C	-	-	-	-	-	-	-	-	C	C	C
Ethanol	C	C	C	C	C	-	C	C	C	C	C	C	C	C	C	C	C	C	C	C	LC
Ethanol 45%	-	-	-	C	-	-	-	C	C	C	C	C	C	C	C	C	C	C	C	C	C
Ethyl Acetate	LC	LC	LC	LC	LC	LC	LC	LC	LC	LC	NC	NC	NC	NC	NC	LC	LC	LC	C	NC	LC
Formaldehyde 0.3%	C	C	C	C	C	C	C	C	C	C	C	C	C	C	C	C	C	C	C	C	C
Formaldehyde 37%	C	C	C	C	C	C	C	C	C	C	-	-	-	-	-	C	C	C	C	C	C
Formic acid conc.	C	C	C	NC	C	C	C	C	NC	NC	-	-	-	-	-	C	C	C	C	NC	NC
Glycerol	C	C	C	C	C	C	C	C	C	C	C	C	C	C	C	C	C	C	C	C	C
Hexane	C	C	C	-	C	C	C	NC	-	-	-	-	-	-	-	-	-	-	NC	NC	NC

	BIO-X II	HIGH FLOW BIO-X	HIGH FLOW BIO-X VENT AUTOCLAVE	HIGH FLOW PREPOR GFA	HIGH FLOW TETPOR II	HIGH FLOW TETPOR H.T.	HIGH FLOW TETPOR VENTAUTOCLAVE	PROCLEAR PP	PROCLEAR GF	PROCLEAR GP	PROPOR MR	PROPOR SG	PROPOR HC	PROPOR BR	PROPOR LR	TETPOR AIR	TETPOR LIQUID	TETPOR PLUS	EPDM o-ring	VITON o-ring	SILICONE o-ring
Hydrochloric acid 1N	-	-	-	C	-	-	-	C	C	C	C	C	C	C	C	C	C	C	C	C	C
Hydrochloric acid conc.	-	-	-	NC	-	-	-	C	NC	NC	-	-	-	-	-	C	C	C	NC	NC	NC
Hydrochloric acid conc.13%	C	C	C	-	C	C	C	-	-	-	-	-	-	-	-	-	-	-	NC	NC	NC
Hydrogen Peroxide	C	C	C	-	-	-	-	C	-	-	-	-	-	-	-	-	-	-	C	C	C
Hydrogen Peroxide 10% Volume	-	-	-	C	-	-	-	C	C	C	C	C	C	C	C	C	C	C	C	C	C
Hydrogen Peroxide 100% Volume	-	-	-	C	C	C	C	C	C	C	-	-	-	-	-	C	C	C	C	C	C
Methanol	C	C	C	C	C	C	C	C	C	C	C	C	C	C	C	C	C	C	C	NC	C
Methyl-Iso-Butylketone	C	C	C	C	C	C	C	C	C	C	NC	NC	NC	NC	NC	C	C	C	NC	NC	LC
Methylene Chloride @ 40°C	-	-	-	LC	-	-	-	LC	LC	LC	-	-	-	-	-	-	-	-	-	-	-
Nitric acid 2N 14.4%	C	C	C	C	C	C	C	C	C	C	C	C	C	C	C	C	C	C	LC	C	C
Nitric acid 15.8N	C	C	C	NC	C	NC	C	C	NC	NC	-	-	-	-	-	C	C	C	NC	NC	NC
Ozone	-	-	-	-	-	-	-	-	-	-	NC	NC	NC	NC	NC	-	-	-	-	-	-
Paraffin yellow	LC	LC	LC	LC	C	C	C	C	LC	LC	-	-	-	-	-	C	C	C	NC	C	NC
Pentane	C	C	C	LC	-	-	-	LC	LC	LC	-	-	-	-	-	LC	LC	LC	NC	C	NC
Peracetic acid 0.5% (10 wk test)	-	-	-	-	C	C	C	-	-	-	-	-	-	-	-	-	-	-	C	C	C
Peracetic acid 4%	C	C	C	C	C	C	C	C	C	C	C	C	C	C	C	C	C	C	C	C	C
Perchloroethylene	-	-	-	-	-	-	-	-	-	-	NC	NC	NC	NC	NC	-	-	-	-	-	-
Petroleum spirits	-	-	-	NC	C	C	C	NC	NC	NC	-	-	-	-	-	LC	LC	LC	NC	C	NC
Phenol (aq) 0.5N	C	C	C	-	NC	-	NC	-	-	-	-	-	-	-	-	-	-	-	-	-	-
Phenol 5%	-	-	-	C	-	-	-	C	C	C	-	-	-	-	-	C	C	C	C	C	C
Phenol 0.25%	-	-	-	C	-	-	-	C	C	C	-	-	-	-	-	C	C	C	C	C	C
Polyethylene Glycol 600	LC	LC	LC	NC	C	C	C	LC	NC	NC	NC	NC	NC	NC	NC	-	-	-	-	-	-
Polyglycol 2000-E	-	-	-	-	-	-	-	-	-	-	-	-	-	-	-	-	-	-	C	C	C
Potassium Dichromate 0.1N	C	C	C	C	C	C	C	C	C	C	-	-	-	-	-	C	C	C	C	C	C
Potassium Iodine 0.6N	C	C	C	C	C	C	C	C	C	C	-	-	-	-	-	C	C	C	C	C	C
Potassium Hydroxide 10N	C	C	C	NC	C	C	C	C	NC	NC	LC	LC	LC	LC	LC	C	C	C	C	C	C
Potassium Permanganate 0.1N	C	C	C	NC	C	LC	C	C	NC	NC	C	C	C	C	C	C	C	C	C	C	C
Propan-1-ol	C	C	C	NC	C	C	C	C	NC	NC	C	C	C	C	C	C	C	C	C	C	LC
Propan-2-ol	C	C	C	NC	C	C	C	C	NC	NC	C	C	C	C	C	C	C	C	C	C	LC
Propan-2-ol, 60:40 H2O	C	C	C	NC	C	C	C	C	NC	NC	C	C	C	C	C	C	C	C	C	C	C
Pyridine	C	C	C	NC	C	C	C	C	NC	NC	NC	NC	NC	NC	NC	C	C	C	C	NC	C
Sodium Chloride 0.5N	C	C	C	C	C	C	C	C	C	C	C	C	C	C	C	C	C	C	C	C	C
Saline Lactose Broth	C	C	C	C	C	C	C	C	C	C	C	C	C	C	C	C	C	C	C	C	C
Sodium Hydroxide 1N 4%	NC	NC	NC	C	C	C	C	C	C	C	C	C	C	C	C	C	C	C	C	C	C
Sodium Hydroxide 7N 28%	NC	NC	NC	NC	C	C	C	C	NC	NC	NC	NC	NC	NC	NC	C	C	C	C	C	LC
Sodium Hypochlorite (14% Free Cl2)	C	C	C	C	C	C	C	C	C	C	C	C	C	C	C	C	C	C	C	C	C

	BIO-X II	HIGH FLOW BIO-X	HIGH FLOW BIO-X VENT AUTOCLAVE	HIGH FLOW PREPOR GFA	HIGH FLOW TETPOR II	HIGH FLOW TETPOR H.T.	HIGH FLOW TETPOR VENTAUTOCLAVE	PROCLEAR PP	PROCLEAR GF	PROCLEAR GP	PROPOR MR	PROPOR SG	PROPOR HC	PROPOR BR	PROPOR LR	TETPOR AIR	TETPOR LIQUID	TETPOR PLUS	EPDM o-ring	VITON o-ring	SILICONE o-ring
Sodium thiosulphate 0.1N	C	C	C	C	C	C	C	C	C	C	-	-	-	-	-	C	C	C	C	C	C
Sulphuric acid 1N	C	C	C	LC	C	C	C	C	LC	LC	C	C	C	C	C	-	-	-	C	C	C
Sulphuric acid conc.	NC	NC	NC	LC	LC	NC	LC	LC	LC	LC	NC	NC	NC	NC	NC	LC	LC	LC	-	-	-
Sulphurous acid	-	-	-	-	-	-	-	-	-	-	NC	NC	NC	NC	NC	-	-	-	-	-	-
Toluene	NC	NC	NC	-	NC	NC	NC	NC	-	-	NC	NC	NC	NC	NC	-	-	-	NC	LC	NC
1,1,1 Trichloroethane	-	-	-	-	-	-	-	-	-	-	-	-	-	-	-	-	-	-	-	-	-
1,1,2 Trichloroethane	C	C	C	LC	C	LC	C	LC	LC	LC	NC	NC	NC	NC	NC	LC	LC	LC	NC	LC	LC
Trichloroacetic Acid 80%	-	-	-	LC	-	-	-	C	LC	LC	-	-	-	-	-	C	C	C	NC	LC	NC
Trichloroacetic Acid 5N	C	C	C	-	C	C	C	-	-	-	-	-	-	-	-	-	-	-	---		
Toluene	-	-	-	NC	-	-	-	-	NC	NC	-	-	-	-	-	-	-	-	NC	LC	NC
Xylene	LC	LC	LC	NC	LC	LC	LC	NC	NC	NC	LC	LC	LC	LC	LC	NC	NC	NC	C	LC	NC

## Chemical Compatibility User Instructions and Notes

- The chemicals are arranged in alphabetical order using their most common or trade names. If the chemical in question does not appear to be listed, it may be found elsewhere in the table under a pseudonym, in particular its IUPAC<sup>10</sup> name.
- **Please note:**
  - Any product that has limited compatibility (LC) at ambient temperatures should not be used at a higher temperature.
  - The list of compatibilities does not take into account any synergistic effects of more than one chemical present in the solution to be filtered.

<sup>10</sup> International Union of Pure and Applied Chemistry

## 5. Cartridge and Capsule Cleanliness

PROPOR LR filters must meet stringent standards to be certified pharmaceutical (P) grade product by Parker domnick hunter. One aspect of this is to confirm levels of potential contaminants that may be added to a process stream by the addition of the filter capsule.

The following tests are designed to determine if contaminants can be released or extracted from the capsule filter and, where identified, a quantitative assessment is made. The PROPOR range of sterilising grade filters all have the same materials of construction and surface areas, they only differ in the micron rating and numbers of layers of membrane. The PROPOR HC dual layer membrane product was selected as a worst case as it utilises two layers of PES membrane.

### 5.1. Gravimetric Non Volatile Extractables in Water

The weight of non-volatile materials extracted from cartridges and capsules was determined during a 10 litre room temperature purified water flush at constant flow to mimic normal operation (methodology defined in Internal Reference IPPF 118 developed from that defined in current USP <661>, Sub section Physicochemical Tests – Plastics.). Five 1 litre aliquots were taken at stepped intervals and assessed. 50 ml of each aliquot was evaporated in an acid washed crucible to constant weight. The NVE mass was identified and reported.

#### Irradiated (45.6 kGy) 'A' size capsule

Cartridge Serial No.	Control	Sample Aliquots No. (mg / 50 ml)					Results
		1	2	3	4	5	
		NVE	NVE	NVE	NVE	NVE	
DC289379	<1	1	<1	<1	<1	<1	<5
DC289376	<1	1	<1	<1	<1	<1	<5
DC289377	<1	1	<1	<1	<1	<1	<5

#### Conclusion

Total NVEs extracted in the first 5 litre flush of purified water for an A size PROPOR capsule is <5 mg.

#### 10" Cartridge

Cartridge Serial No.	Control	Sample Aliquots No. (mg / 50 ml)					Results
		1	2	3	4	5	
		NVE	NVE	NVE	NVE	NVE	
P013113	1	<1	1	<1	<1	<1	<5
P013647	1	3	1	1	<1	1	<7
P013100	0	3	4	1	<1	<1	<10

#### Conclusion

Total NVEs extracted in the first 5 litre flush of purified water for a 10 inch cartridge is <10 mg.

## 5.2. Buffering Capacity

The impact on buffering capacity of materials extracted from PROPOR cartridges and capsules was determined during a 10 litre room temperature purified water flush at constant flow. Five 1 litre aliquots were taken at stepped intervals and assessed using a protocol developed from that defined in current USP <661>, Sub section Physicochemical Tests – Plastics.

The volume of 0.01N hydrochloric acid or 0.01N sodium hydroxide required to bring each of the 20 ml extracts and 20 ml control samples to pH 7 was compared and reported. If the difference in the volumes added is less than 10 ml, the potential impact of the extract as a buffer is considered acceptable.

### Irradiated (45.6 kGy) 'A' size capsule

Cartridge Serial No.	Control		Sample Aliquots No.										Result
			1		2		3		4		5		
	Initial pH	ml added	Initial pH	ml added	Initial pH	ml added	Initial pH	ml added	Initial pH	ml added	Initial pH	ml added	
DC289379	6	1	6	1	6	1	6	1	6	1	6	1	Pass
DC289376	7	0	7	0	7	0	7	0	7	0	7	0	Pass
DC289377	7	0	7	0	7	0	7	0	7	0	7	0	Pass

### Conclusion

The difference in the volumes added was less than 10 ml and therefore, the potential impact of the extract as a buffer is considered acceptable.

### 10" Cartridge

Cartridge Serial No.	Control		Sample Aliquots No.										Result
			1		2		3		4		5		
	Initial pH	ml added	Initial pH	ml added	Initial pH	ml added	Initial pH	ml added	Initial pH	ml added	Initial pH	ml added	
P013113	6	1	6	1	6	1	6	1	6	1	6	1	Pass
P013647	6	1	6	1	6	1	6	1	6	1	6	1	Pass
P013100	6	1	6	1	6	1	6	1	6	1	6	1	Pass

### Conclusion

The difference in the volumes added was less than 10 ml and therefore, the potential impact of the extract as a buffer is considered acceptable.

### 5.3. Bacterial Endotoxins

Pyrogenicity, or the concentration of bacterial endotoxins, extracted from PROPOR LR cartridges and capsules was determined during a 10 litre room temperature purified water flush at constant flow. Five 1 litre aliquots were taken at stepped intervals and assessed using protocols defined in current USP <85>.

#### Irradiated (45.6 kGy) 'A' size capsule

Cartridge Serial No.	Controls		Sample Aliquots No. (-ve or +ve Gel in Duplicate)					Result
	-ve	0.25 EU / ml	1	2	3	4	5	
DC289379	-	+	-	-	-	-	-	Pass
DC289376	-	+	-	-	-	-	-	Pass
DC289377	-	+	-	-	-	-	-	Pass

#### Conclusion

Aqueous extracts from the A size PROPOR LR capsule were shown to contain < 0.25 EU / ml when tested in accordance with the Limulus Amoebocyte Lysate (LAL) test.

#### 10" Cartridge

Cartridge Serial No.	Controls		Sample Aliquots No. (-ve or +ve Gel in Duplicate)					Result
	-ve	0.25 EU / ml	1	2	3	4	5	
P013113	-	+	-	-	-	-	-	Pass
P013647	-	+	-	-	-	-	-	Pass
P013100	-	+	-	-	-	-	-	Pass

#### Conclusion

Aqueous extracts from the 10 inch PROPOR LR were shown to contain < 0.25 EU / ml when tested in accordance with the Limulus Amoebocyte Lysate (LAL) test.

## 5.4. Particle and Fibre Shedding

The levels of particles and fibres released from PROPOR LR cartridges and capsules were determined. Three capsules from different production lots were flushed with one litre of purified water. Samples from subsequent aliquots up to a 10 litre flush were monitored using on-line particle counting and sizing in accordance with the requirements of:

- a) Current USP <788> Particulate Matter in Injections, Sub Section Light Obscuration Particle Count Test – Large Volume Injections
- b) EP2.9.19 – Particulate Contamination: Sub-Visible Particles – Method 1. Light Obscuration Particle Count Test.
- c) Allowable limits:
  - <25 particles per ml @  $\geq 10 \mu\text{m}$
  - <3 particles per ml @  $\geq 25 \mu\text{m}$

### Irradiated (45.6 kGy) 'A' size capsule

Cartridge Serial No	Size Bands $\mu\text{m}$	Average Counts per ml in 1 Litre Samples Taken Post 1 Litre Pulse						Result
		Clean Water Control	2 <sup>nd</sup> Litre	4 <sup>th</sup> Litre	6 <sup>th</sup> Litre	8 <sup>th</sup> Litre	10 <sup>th</sup> Litre	
DC289379	>2	0.00	0.04	0.00	0.00	0.00	<b>Pass</b>	
	>5	0.00	0.03	0.00	0.00	0.00		
	>10	0.00	0.03	0.00	0.00	0.00		
	>25	0.00	0.02	0.00	0.00	0.00		
DC289376	>2	0.00	0.71	0.00	0.00	0.00	<b>Pass</b>	
	>5	0.00	0.51	0.00	0.00	0.00		
	>10	0.00	0.38	0.00	0.00	0.00		
	>25	0.00	0.17	0.00	0.00	0.00		
DC289377	>2	0.00	2.61	0.51	0.19	0.07	<b>Pass</b>	
	>5	0.00	0.73	0.03	0.01	0.00		
	>10	0.00	0.03	0.00	0.00	0.00		
	>25	0.00	0.00	0.00	0.00	0.00		

### Conclusion

All filters conform to the requirements of USP<788> and EP2.9.19 within the first 2 litres of a purified water flush.

**10" Cartridge**

Cartridge Serial No	Size Bands $\mu\text{m}$	Average Counts per ml in 1 Litre Samples Taken Post 1 Litre Pulse					Result
		Clean Water Control	2 <sup>nd</sup> Litre	4 <sup>th</sup> Litre	6 <sup>th</sup> Litre	8 <sup>th</sup> Litre	
P013113	>2	0.68	3.26	0.89	0.76	0.57	<b>Pass</b>
	>5	0.15	1.12	0.27	0.27	0.17	
	>10	0.06	0.36	0.08	0.10	0.05	
	>25	0.04	0.04	0.01	0.01	0.00	
P013647	>2	0.04	12.76	4.73	4.19	1.19	<b>Pass</b>
	>5	0.01	4.92	1.78	1.40	0.64	
	>10	0.00	2.42	0.84	0.57	0.29	
	>25	0.00	0.34	0.10	0.09	0.04	
P013100	>2	0.00	4.93	1.92	1.01	0.52	<b>Pass</b>
	>5	0.00	0.75	0.18	0.10	0.05	
	>10	0.00	0.23	0.05	0.02	0.01	
	>25	0.00	0.04	0.01	0.00	0.00	

**Conclusion**

All filters conform to the requirements of USP<788> and EP2.9.19 within the first 2 litres of a purified water flush.

## 5.5. Oxidizable Substances

The level of oxidizable substances extracted from a PROPOR LR cartridge and capsule was determined during a 10 litre room temperature purified water flush at constant flow. Five 1 litre aliquots were taken at stepped intervals and assessed using the method defined in the Monograph: Water, Purified, of the current European Pharmacopoeia (identified as an alternative to TOC (2.2.44)).

To 100 ml of extract, 10 ml of dilute sulphuric acid and 0.1 ml of 0.2 M potassium permanganate was added and boiled for 5 minutes. The extracts from the three test cartridges must remain pink to indicate an acceptable level of oxidizable substances.

### Irradiated (45.6 kGy) 'A' size capsule

Cartridge Serial No.	Control		Sample Aliquots No. (Purple / Pink Colour Remains)					Result	
	+ve	-ve	1	2	3	4	5		
DC289379	No	Yes	Yes	Yes	Yes	Yes	Yes	Yes	Pass
DC289376	No	Yes	Yes	Yes	Yes	Yes	Yes	Yes	Pass
DC289377	No	Yes	Yes	Yes	Yes	Yes	Yes	Yes	Pass

### Conclusion

PROPOR LR filter capsules meet current USP quality standards for oxidizable substances within the first 1 litre flush with purified water.

### 10" Cartridge

Cartridge Serial No.	Control		Sample Aliquots No. (Purple / Pink Colour Remains)					Result	
	+ve	-ve	1	2	3	4	5		
P013113	No	Yes	Yes	Yes	Yes	Yes	Yes	Yes	Pass
P013647	No	Yes	Yes	Yes	Yes	Yes	Yes	Yes	Pass
P013100	No	Yes	Yes	Yes	Yes	Yes	Yes	Yes	Pass

### Conclusion

PROPOR LR filter cartridges meet the requirements of the current EP and USP quality standards for oxidizable substances within the first 1 litre flush with purified water.

## 5.6. Total Organic Carbon and Ionic Substances

TOC levels were determined for the PROPOR LR cartridges and capsules in accordance with standard production process and production specifications. Immediately after the flush, 200 ml is assessed for TOC and conductivity by an on line analyser. Measured TOC and conductivity levels are recorded.

The test method for TOC is in accordance with current USP <643> and EP 2.2.44. The test method for conductivity is in accordance with current USP <645> and EP 2.2.38.

Acceptable TOC limit: <500ppb

Acceptable conductivity limit: <1.3  $\mu$ S / cm @ 25°C

### Irradiated (45.6 kGy) 'A' size capsule

Cartridge Serial No.	Filtrate Sample		Results	
	TOC (ppb)	Conductivity ( $\mu$ S/cm)	TOC (ppb)	Conductivity ( $\mu$ S/cm)
DC289379	420	0.075	Pass	Pass
DC289376	145	0.061	Pass	Pass
DC289377	160	0.119	Pass	Pass

### Conclusion

The filtrate quality from an A size PROPOR LR capsule conforms to the requirements of USP <643> (TOC) and USP <645> (conductivity) within the first 200 ml flush of purified water.

### 10" Cartridge

Cartridge Serial No.	Filtrate Sample		Results	
	TOC (ppb)	Conductivity ( $\mu$ S/cm)	TOC (ppb)	Conductivity ( $\mu$ S/cm)
P013655	258	0.070	Pass	Pass
P135339	205	0.070	Pass	Pass
P135344	180	0.071	Pass	Pass
P012430	170	0.076	Pass	Pass
P135342	215	0.072	Pass	Pass
P135341	195	0.071	Pass	Pass

### Conclusion

The filtrate quality from a 10 inch PROPOR LR conforms to the requirements of USP <643> (TOC) and USP <645> and EP 2.2.38 (conductivity) within the first 200 ml flush of purified water.

## 5.7. Determination of extracted chemical compounds<sup>11</sup>

To assist in planning validation studies for a particular drug product, extraction tests in WFI (70°C for 24hrs) have been conducted to identify the compounds that could potentially leach into a drug product during aseptic filtration. This information can be used to assess potential toxicological effects of the leachable substances in-line with ISO 10993-17 "Methods for the establishment of allowable limits for leachable substances using health based risk". The tests were conducted on products from the PROPOR range utilising the same materials of construction.

The analysis was performed on combined extracts from three 0.1m<sup>2</sup> filter cartridges pre and post autoclaving @ 130°C for 30 minutes. Extraction conditions for the cartridges were a static soak for 24 hours at 70°C. The results reported below are an average per cartridge for the three tested.

### Metals Analysis via ICP-AES

Metals	Mass extract mg /cartridge	
	Pre autoclave	Post Autoclave
Ba	<0.04	<0.04
Ca	<0.06	<0.06
Cd	<0.04	<0.04
Co	<0.05	<0.05
Cr	<0.04	<0.04
Cu	<0.04	<0.04
Fe	<0.04	<0.04
K	<0.04	<0.04
Mg	<0.04	<0.04
Mn	<0.04	<0.04
Na	<0.04	<0.04
Ni	<0.08	<0.08
Pb	<0.08	<0.08
Zn	<0.04	<0.04

NOTE: All metal extracts were below the limit of detection of the instrumentation

### Conclusion

All potential metal extracts were below the limit of detection of the instrumentation.

<sup>11</sup> Product formats, solutions and process conditions may influence type and concentration of leachables observed.

### Headspace GC/MS

Volatile organic molecules that migrate into the contact solution during a prolonged contact step between a medical device or a test material and the extraction solution, may come from various sources such as monomer residues, solvent residues from various production steps, residues from polymer treatments or smaller polymer breakdown products.

The selected technique for this analytical method – Headspace coupled to a Gas Chromatography (GC) with Mass Spectrometry (MS) allows identification of the target analytes based on both retention time of the analytes in the chromatogram and the mass spectrum of the eluting compound at this specific retention time.

No compounds could be detected at a higher concentration than the method reporting limit of 79µg / cartridge.

### Dichloromethane Extraction (DCM) + GC/MS

This analytical technique is used to identify potential migration of organic components. To improve the sensitivity of the total analytical method, the water samples were extracted with an organic solvent (DCM) with a low boiling point. Following extraction, the DCM phase was concentrated down to 2 ml to further enhance sensitivity.

The compounds identified were

- Butyrolactone
- 4-butoxy-1-butanol
- Caprolactam
- Azacyclotridecan-2-one

### Dichloromethane Extraction (DCM) + LC/MS

This analytical technique is used to identify non-volatile or non-thermostable components such as anti-oxidants, plasticizers etc. To improve the sensitivity of the total analytical method, the water samples were extracted with an organic solvent (DCM) with a low boiling point. Following extraction the DCM phase was concentrated down to 2 ml to further enhance sensitivity.

The compounds identified were

- Erucamide

## 6. Tests for Biocompatibility

An independent research establishment has assessed the biological safety associated with the use of PROPOR LR filters designed for processing pharmaceutical products.

The materials used in the construction of PROPOR LR products meet the requirements of the current USP <88> Biological Reactivity tests at Plastics Class VI – 121°C. A matrix of test reports is given below:

Component	Material Description	Report References	Testing Agency
Endcaps	Injection Moulded Nylon	07-4844-G1	HRC Ltd. & Toxikon Corp.
Core	Injection Moulded Polypropylene	881320D/DHF 18/AC 881327D/DHF 19/AC 881344D/DHF 20/AC	HRC Ltd.
Filtration Membranes	Cast Polyethersulfone Membrane	99G-0108	Toxikon Corp.
Membrane Supports	Spunbond Polyester non-woven.	90676D/LML 1/AC 90678D/LML 3/AC 90677D/LML 2/AC	HRC Ltd.

## **7. Certificate of Conformance**

To certify that Parker domnick hunter's PROPOR LR filter products meet the highest pharmaceutical quality and performance requirements, a Certificate of Conformance is issued.

## Documentation Approval Section

### Q.A. Approval

Approved By: Martin Newman

Title: Senior Quality Engineer

Date: April 2017

### Technical Approval

Approved By: Andrew Kelly

Title: Product Manager (Life Science)

Date: April 2017



Durham Road, Birtley, Co. Durham  
England, UK. DH3 2SF  
Tel: +44 (0)191 4104450  
Fax: +44 (0)191 4105312  
E-mail: [dhprocess@parker.com](mailto:dhprocess@parker.com)  
Website: [www.parker.com/dhpharma](http://www.parker.com/dhpharma)

Parker domnick hunter has a policy of continuous product development and although the Company reserves the right to change specification, it attempts to keep customers informed of any alterations. This publication provides generic validation information only and customers are requested to contact the Process Division for detailed information and advice on a product's suitability for specific applications.